

**PERMIT REPORT**

To: Board of Managers

From: Elizabeth Showalter, Permitting Technician

Date: January 7, 2018

Re: Minneapolis Park & Recreation Board; Permit 18-635: Lake Nokomis Shoreline

Recommendation:

Approval of MCWD permit application on the following conditions:

1. Identification of the contractor responsible for implementing the erosion control plan;
2. Submission of an NPDES permit;
3. Execution of a maintenance agreement for maintenance wetland buffers and hydraulic structures, including:
 - a. A wetland buffer signage plan including signs with a maximum spacing of every 100 feet
 - b. Confirmation by staff that the plan is consistent with MCWD buffer-maintenance standards

And stipulation:

1. The maximum encroachment of riprap in “Shoreline Stabilization Style 1” shall be ten feet waterward from the Ordinary High Water Level.

Approval of a Wetland Conservation Act no-loss determination, exemption, and revision of a boundary and type determination on the following conditions:

1. Use of erosion control materials designed to prevent entanglement of animals such as natural netting, rectangular netting, or flexible netting.

Background:

The Minneapolis Park and Recreation Board (Applicant) has applied for a Minnehaha Creek Watershed District (MCWD) permit for the enhancement of the shoreline of Lake Nokomis and replacement of two stormwater outfalls. The project goals include increasing the natural landscape, reduction in impacts from invasive vegetation around the lake, and improvement of recreation access to the lake. The project is an integral part of the park Master Plan. The applicant has requested an exception from the buffer provision of the Wetland Protection Rule. The application was complete on November 14, 2018.

The project triggers the District’s Erosion Control, Floodplain Alteration, Wetland Protection, Shoreline and Streambank Stabilization, and Waterbody Crossings and Structures rules. The applicant also has sought approval of the work under the Wetland Conservation Act, which is administered by the District in the City of Minneapolis. Additionally, the project plans show a



shortfall from the applicable wetland buffer requirement, therefore the applicant has requested approval of an exception.

The Applicant is seeking authorization under DNR General Permit 2001-6009, which authorizes work in public waters subject to MCWD Rules. Staff has notified the DNR area hydrologist of the project, who concurred the project is within the scope of the general permit.

District Rule Analysis:

Erosion Control Rule

The District’s Erosion Control Rule is applied to projects proposing 5,000 square feet of disturbance or 50 cubic yards of fill, excavation, or stockpiling on-site. The Applicant is proposing 4.5 acres of disturbance, therefore the rule is triggered. In accordance with the rule provisions, the Applicant has submitted an erosion control plan which identifies erosion and sediment control best management practices. These include a rock construction entrance, silt fence down gradient of disturbed areas, concrete washout locations utilizing impermeable liners, and inlet protection where necessary. The total disturbed area is less than 5 acres, therefore a temporary sediment basin is not required under the Rule Policy for MS4 Compliance (Resolution 15-054). Additionally, a vegetative stabilization plan including the incorporation of six-inches of topsoil into underlying soils prior to final stabilization has also been provided.

Identification of the responsible contractor and submission of an NPDES permit are listed as recommended conditions of approval. Upon satisfaction of the recommended conditions, the project meets the Erosion Control Rule.

Floodplain Alteration

The Floodplain Alteration Rule is triggered whenever land altering activity is proposed beneath the 100 year flood elevation of any waterbody. The Applicant is proposing disturbance in the floodplain of Lake Nokomis, therefore the rule is triggered. The applicant is proposing grading for the shoreline restoration that will flattening out eroded slopes with disturbance exclusively between the 100 year elevation (819.7) and OHW (815.4) with no additional material or removal of material and cut and fill for the two outfall replacements which results in a creation of flood storage, as shown in the table below.

As stated in the District’s Floodplain Alteration Rule section 3(a), “fill shall not cause a net decrease in storage capacity below the projected 100-year high water elevation of a waterbody.” As shown in Table 1 below, the applicant is increasing the flood storage capacity of Lake Nokomis by 119 cubic feet. The grading for the shoreline stabilization is confined to the floodplain and will be a field fitting exercise with no addition of new material, as shown in the plans. The applicant has, therefore met section 3(a).

	Total Fill (cf)	Total Cut (cf)
North Outfall	239	0
South Outfall	0	358

Table 1: Floodplain Cut and Fill



Section 3(b) of the rule requires no increase in the 100-year flood elevation of a watercourse. The project does not involve a watercourse, therefore the provision does not apply.

Section 3(c) of the rule states that section 3(a) of this rule does not apply to fill in a waterbasin if the applicant shows that the proposed fill, together with the filling of all other properties on the waterbody to the same degree of encroachment will not cause high water or aggravate flooding on other properties. Because there is a net gain in flood storage space, section 3(c) of the rule does not apply to this project.

Section 3(d) of the rule requires that no new impervious surface be created in the lesser of 25 feet of the centerline of a watercourse or the 10 year floodplain, unless that surface is an integral component of a linear public roadway or trail. No new impervious surface is proposed within the floodplain.

Section 3(e) of the rule is not applicable, as no ice ridge grading is proposed.

Section 3(f) of the rule requires that the low openings to all structures be a minimum of 2 feet above the 100 year high water elevation. No structures are proposed and all existing structures have low openings at least 2 feet above the 100 year high water elevation.

Therefore, the project meets the Floodplain Alteration Rule.

Wetland Conservation Act

The wetland boundary and types were delineated on in September of 2017 and approved by the District on December 6, 2017 (Attachment 5). The delineation indicated the location of all water resources, not only wetlands subject to regulation under WCA. During a later Technical Evaluation Panel (TEP) meeting, the TEP determined that an eroded point which was identified as wetland, is more accurately considered part of the deepwater habitat of Lake Nokomis and should not be indicated as wetland. The TEP reviewed a revised boundary (included in the Joint Application Form-Attachment 2) and determined that the boundary should be revised as part of the applicant's no-loss application.

The Wetland Conservation Act regulates draining, filling, and excavation in wetlands. The project is proposing grading in the wetlands as part of the shoreline restoration to repair erosion and establish native vegetation. Under 8420.0415 D, activities conducted by public agencies for the purpose of wetland restoration or fish and wildlife habitat restoration qualify for a no-loss determination if they are conducted in accordance with restoration guidance cited in the WCA rule.¹ The proposed project is being conducted for wetland and habitat restoration in accordance with the guidance referenced in the WCA, and therefore meets the no-loss criteria, and

¹ Wetland Restoration Guide, Minnesota Board of Water and Soil Resources (December 1982) and Wildlife Habitat Improvements in Wetlands: Guidance for Soil and Water Conservation Districts and Local Government Units in Certifying and Approving Wetland Conservation Act Exemption Proposals, Minnesota Interagency Wetlands Group, December 2000.



replacement is not required. The project will be achieving the restoration through the repair of erosion along the shoreline and establishment of native vegetation that will provide long term bank stability and wetland habitat for aquatic and terrestrial species.

The applicant is also proposing the replacement of two stormwater outfalls that contribute to the bank erosion. The two outfalls will result in a total wetland impact of 454 square feet. The north outfall currently enters the lake at an angle, which causes scour into the bank. To reorient it to enter perpendicular to the bank some wetland impacts are proposed. The eastern outfall is made up of two pipes which currently outfall separately and the applicant is proposing to construct a box culvert to allow access to the pipes for maintenance. Further analysis of alternatives explored is provided in the Waterbody Crossings and Structures section. Under 8420.0420 Subp. 6., replacement is not required for impacts resulting from installation, maintenance, or repair of utility lines if impacts have been avoided and minimized to the greatest possible extent and it does not propose alteration or modification to more than one half acre of wetland. The applicant has demonstrated the proposed alternative is minimally impactful (a thorough alternatives analysis regarding the placement of utilities is provided under the Waterbody Crossings and Structures heading) and the proposed impact is less than one half acre, therefore, the utilities exemption applies.

The Notice of Application for the no-loss determination and exemption approval was provided to the Technical Evaluation Panel (TEP) and the TEP met on November 30, 2018. A comment was received from the DNR requesting the applicant be required to utilize wildlife friendly erosion control products with natural or biodegradable netting, rectangular netting and/or non-welded mesh instead of the traditional photodegradable plastic square netting which poses a risk for entanglement of small animals. Otherwise, the TEP determined that the project qualified under the requested no-loss and exception criteria, and recommended revision of the approved boundary. Staff recommends approval of the exemption and no-loss determination and approval of a revised wetland boundary with the condition that erosion control products used be designed to prevent entanglement of animals.

Wetland Protection

The buffer provision of the Wetland Protection Rule is applicable whenever MCWD's Waterbody Crossings and Structures Rule is triggered. Since disturbance is proposed for the enhancement of the shoreline and buffer areas, the buffer provision of the Wetland Protection rule is applicable.

The project site contains a fringe wetland present along the shoreline of Lake Nokomis. The wetland was only delineated in the areas proposed for disturbance, but does extend around much of the shoreline of the lake. The portions not exhibiting wetland characteristics are primarily either beaches or have intact WPA retaining walls.

Per section 5(a) of the Wetland Protection rule, buffers must be provided around all disturbed wetlands and on wetland edges downgradient of disturbance. The applicant has provided plans including wetland buffers on all disturbed wetland and wetland contiguous to disturbed wetland. Portions of the shoreline with wetland present that are separated by upland from disturbed



wetland have not had buffers applied. Additional analysis on buffer width has been provided under section 6(c) below.

Per section 5(b) of the rule, buffers are required, and have been analyzed under section 6, below.

Per section 5(c) of the rule, buffers must be documented by a declaration or other recordable instrument. The Minneapolis Park and Recreation Board does not have a programmatic maintenance agreement, and therefore a project specific agreement is listed as a recommended condition of approval to satisfy this requirement.

Section 5(d) of the rule requires a permanent wetland buffer monument to be installed at each lot line where it intersects the buffer, and where needed to indicate the contour of the buffer, with a maximum spacing of 100 feet. This requirement has been analyzed and satisfied under section 7(b) below, as the Applicant will be submitting a conforming maintenance agreement with the District including the locations of the required monuments.

Per section 6(a) of the rule, buffer width requirements are determined by the management class of the wetland (Table 2). The District’s Functional Assessment of Wetlands did not identify the shoreline wetland and therefore a management class was not assigned. The Minnesota Routine Assessment Method (MnRAM) classifies the wetland as a Preserve, the most protected management class, which corresponds to a 75-foot buffer. The Applicant has requested a reduction in buffer width to a width of 67 feet due to Type A soils (allowing a reduction of 6 feet) and 10% slopes (allowing a reduction of 4 feet).

Management Class	Base Buffer Width	Minimum Applied Buffer Width
Manage 3	20 feet	16 feet
Manage 2	30 feet	24 feet
Manage 1	40 feet	34 feet
Preserve	75 feet	67 feet

Table 2: Wetland Management Classifications & Buffer Widths

Per section 6(c) of the rule, buffer averaging is permitted should the full width of the buffer not be able to be provided in all locations. Under this provision of the rule, buffer averaging may encompass minimum buffer widths of 37.5 feet, with a maximum width of 150 feet for Preserve wetlands, provided that there is no reduction in total buffer area (assumes an area equal to a uniform 75 foot buffer along the length of the wetland). Based on review of the plans and specifications, the project as proposed does not meet MCWD buffer requirements in two ways: the applicant has not provided the required buffer area or met the minimum buffer widths. The buffer is width is not being met due to existing structures and the desire to maintain park space for recreation. The Applicant has requested an Exception to section 6(c) of the Wetland Protection rule, which has been analyzed under the ‘Exception’ heading below.



Section 6(d) of the rule does not apply as the Applicant has not requested a reduction in Applied Buffer Width based on the proposed buffer providing value equal to or greater than would be provided by a buffer of the applicable Applied Buffer Width.

Section 6(e) of the rule does not apply as this is not a Linear Reconstruction Project.

Section 6(f) of this rule does not apply as this project is not a New Principal Residential Structure.

The applicant has submitted plans and specifications sufficient to show conformance with section 7(a) of the Wetland Protection rule, which prohibits actions such as mowing, fertilizing or placement of yard waste within the buffer area. Submission of a maintenance agreement including these provisions is listed as a recommended condition of approval.

Section 7(b) of the rule allows public land, homeowners associations, and right-of-way to comply with buffer monumentation, buffer monitoring, and vegetation management through a written maintenance agreement with the District that provides for compliance with the MCWD monumentation, monitoring and vegetative-management requirements. The applicant provided a maintenance and monitoring plan for the first five year of vegetation establishment including performance standards for each year. The plan includes spot herbicide treatment of invasive species and mowing. If the performance standards for percent native cover and species diversity are not met, the applicant will prepare a remedial plan which will be submitted to the District as required by the maintenance agreement.

Per section 7(c) of the rule, any buffer areas that will be disturbed by grading or other site activities during construction must be replanted and maintained according to the following standards:

- Soils must be decompacted to a depth of 18 inches and organic matter must be incorporated into soils before revegetation;
- Erosion/sediment control practices consistent with the requirements of the District Erosion Control rule must be employed during buffer establishment;
- Buffers shall be planted with a native seed mix and/or native plantings approved by the District; and
- Buffer maintenance and monitoring shall be performed and meet the standards of the District's Wetland Buffer Monitoring requirements.

Review of the plans, specifications, and additional information the Applicant submitted showed large portions of the proposed buffer will be disturbed by construction, and therefore will be subject to the items listed above. The Applicant has provided information that sufficiently addresses the requirements, including specifications for decompaction of soils, submission of an erosion control plan, and native seed mix specifications (Pilot State Seed Mix: Low-Growing Solar Array South and West). The Applicant meets the requirement of section 7(c) of the Wetland Protection rule.



In summary, upon satisfaction of the recommended conditions, the project meets the requirements of the Wetland Protection Rule, apart from section 6(c), as noted above, for which the Applicant has requested an Exception.

Shoreline and Streambank Stabilization

The Shoreline and Streambank Stabilization Rule regulates alterations and improvements to the banks of watercourses. The project is proposing stabilization of approximately 4,800 linear feet of shoreline through three treatments. A severely eroded point will be stabilized with riprap with an area between 1 and 2 feet above the OHW vegetated, and all areas at the elevation 1 foot above the OHW and below will be strictly structural stabilization. Two stormwater outfalls are being replaced and energy dissipation will be installed at the outfalls consisting of riprap with cordgrass joint plantings, and the rest of the project area which will be stabilized through strictly vegetative means utilizing seed and plant plugs with coir logs and erosion control blanket.

Per sections 2(b) and 3(a) of the rule, applications for shoreline stabilization must complete the Erosion Intensity Scoresheet. The applicant completed the scoresheet for the three areas proposed for structural stabilization. Based on this information, the Applicant has met section 3(a) of the rule.

Per section 3(b) of the rule, the proposed stabilization practice must be consistent with the shoresheet. The first area proposed for structural stabilization is a point on the east side of the lake which scored in the “high” category (score of 51, high is between 49 and 78) which permits the use of structural stabilization. The applicant is proposing to use a combination of riprap with some vegetation starting one foot above the OHW. The areas with proposed outfall replacement scored in the “medium” category (score of 38, medium is between 31 and 48) which permits the use of bioengineered techniques. Bioengineering is proposed for the stabilization of the two outfalls utilizing riprap with cordgrass planted in the joints. The rest of the shoreline scores in the medium category (score of 38), allowing bioengineering or biological stabilization. The applicant has proposed biological stabilization in the area.

Per section 5 of the rule, the District may approve alternative stabilization techniques if the applicant provides sufficient evidence to demonstrate that the proposed stabilization practice represent the minimal impact solution with respect to all other reasonable alternatives. The applicant is exclusively proposing stabilization techniques that fall within the allowed range of stabilization techniques based on the erosion intensity scores.

Per section 6(a) of the rule, the applicant must demonstrate:

- The installation of structural stabilization practices occurs only where there is a demonstrated need to prevent erosion or to restore eroded shoreline/streambank;
 - The applicant has submitted documentation of the erosion that has occurred on the shoreline at the areas proposed for stabilization.
- Removal of native vegetation within the streambank stabilization zone is limited, especially clear cutting within the access corridor and preservation of native vegetation outside of the access corridor;



- Most vegetation in the project area will be removed, but will be replaced with native vegetation that provides greater habitat and water quality benefits. The extant vegetation is either invasive or is maintained as turf.
- Stabilization practices are installed at a 3:1 slope or flatter where practical or feasible;
 - The Applicant has submitted plans and cross-sections showing rip-rap 2.5:1 slope due to the steep bathymetry of the shoreline. Based on staff and the District Engineer's analysis, the Applicant has met this criteria of the rule.
- Encroachment from shorelines shall be minimized to the greatest extent practical, typically no more than 5 feet waterward, and with a maximum encroachment of 10 feet.
 - The Applicant has submitted plans depicting a 2.5:1 slope, due to the steep bathymetry in the area to meet the ten foot maximum encroachment. The ten foot maximum encroachment is not specified in the plans, and is therefore included as a recommended stipulation on the permit.
- Stabilization practices cannot reduce the cross-sectional area of the channel nor result in a net increase in the flood stage upstream or at the site of the streambank stabilization practice unless it can be demonstrated to not exacerbate high-water conditions;
 - The project does not involve stabilization of a streambank.
- Streambank stabilization practices shall conform to the natural alignment of the bank;
 - The stabilization practices maintain the undulating shoreline of the lake.
- The design shall reflect the engineering properties of the underlying soils and any soil corrections or reinforcements. For a streambank, design shall conform to engineering principles for the hydraulic behavior of open-channel flow;
 - The Applicant has submitted plans including grading the underlying soils to support the proposed stabilization plans which are designed to reflect the fill soils present on the shoreline. The District Engineer has reviewed the plans and concurs the plans are appropriate for the characteristics of the underlying soils.
- For sites involving aquatic plantings or removals, a separate Aquatic Plant Management Permit shall be obtained from the DNR, when applicable;
 - No aquatic plant management is proposed, therefore the criteria is not applicable.
- Any work below the OHW shall be encircled by a floatation sediment curtain;
 - The applicant has submitted an erosion control plan including the use of floating silt curtain.

In summary, the Applicant has demonstrated, and staff and the District Engineer concur that all applicable aspects of section 6(a) of the rule have been met.

Per section 6(b) of the rule, the applicant must meet the following criteria for bio-engineering techniques:

- Live plantings incorporated into the shoreline or bank shall be native aquatic and/or native upland vegetation known to occur in the North Central Hardwood Forest eco-region of Minnesota;
 - All proposed seed and plant plugs are native to the area and appropriate to the conditions.



- Vegetative treatments shall be installed in accordance with the Natural Resource Conservation Service “Engineering Field Handbook Chapter 16”
 - The proposed shoreline stabilization, as shown in the construction and landscape plans, is designed in accordance with the referenced resource. The Applicant has met this criteria of the rule.
- If wave barriers are utilized, they shall be located within the 3 foot water depth or less and may not create obstruction to navigation. Wave barriers shall be removed within 2 years of installation.
 - The wave barriers will be located in areas with 2 foot water depth and will be only located in areas where emergent vegetation is proposed. The plans indicate the barriers will be removed within 2 years of installation.
- Bio-engineered stabilization also must comply with the criteria in 6(c)(1-3) and (5).
 - This has been analyzed below.

Per section 6(c) of the rule, the applicant must meet the following criteria for structural stabilization:

- Hard-armoring inert material, such as riprap, shall be considered wetland fill only if proposed to be placed within an area identified as wetland.
 - No riprap is proposed within wetlands.
- Riprap shall extend no higher than the top of the bank, or two feet above the 100-year high water elevation, whichever is lower;
 - Per the plans and cross-sections submitted by the Applicant, staff and the District Engineer have determined that hard-armoring stabilization practices will be placed at the top of the bank, below the 100-year flood elevation of the new channel. Based upon this analysis, the Applicant has met this criteria of the rule.
- Riprap materials shall be durable stone meeting the size and gradation requirements of MnDOT Class III or IV riprap. Toe boulders shall be at least 50% buried and may be as large as 30 inches in diameter.
 - Per the plans, cross-sections, and specifications submitted by the Applicant, staff and the District Engineer have determined that the materials utilized for hard-armoring meet the criteria for MnDOT Class IV riprap, and all toe boulders are anchored at least 50% in the underlying substrate. Based upon this analysis, the Applicant has met this criteria of the rule.
- A transitional granular filler meeting requirements of MnDOT 3601.B, at least 6 inches in depth, shall be placed between the native shoreline and the riprap to prevent erosion of fine grained soils. A geotextile filter fabric meeting the requirements of MnDOT 3733 shall be placed beneath the granular filler where appropriate.
 - Per the plans, cross-sections, and specifications submitted by the Applicant, staff and the District Engineer have determined that the granular filler and geotextile fabric meet the requirements and specifications of MnDOT 3601.B and MnDOT 3733. Based upon this analysis, the Applicant has met this criteria of the rule.



- Structural stabilization practices, including riprap, are recommended to include plantings between individual boulders or native upland plantings to retard runoff and prevent erosion wherever feasible and practical.
 - Lake Nokomis is part of the Grand Rounds historic district and therefore, federal approvals involve a review of impact to cultural resources, through coordination with the State Historic Preservation Office (SHPO). In preapplication consultation with the SHPO, MPRB was encouraged to design the project to mimic the historic condition of Lake Nokomis (the historic condition being the post dredging condition with retaining walls on most banks). Unvegetated riprap more closely mimicked the retaining walls and was therefore the selected alternative. Upland buffer will be established upgradient of the riprap at the point and the uppermost foot of the riprap will be vegetated with soil placed on top of the rock. The applicant is proposing planting the joints of the riprap at the outfalls with cordgrass.

In summary, the Applicant has demonstrated, and staff and the District Engineer concur, that all applicable aspects of section 6(b) and (c) of the rule have been met.

Section 8(a-d), and 9(a-c) regulate the placement of sandblankets. Restoration of vegetation above sand beaches will be modified by the proposed project, but no additional sand is proposed, therefore this section does not apply.

Section 10(a-d) of the rule are not applicable, as no retaining walls are proposed with the project.

Section 11 regulates boat ramps and other shoreline improvements. No new boat ramps or canoe launches are proposed or will be modified.

In summary, based on the analysis of staff and the District Engineer provided above, the applicant has met all the applicable criteria of the Shoreline and Streambank Stabilization rule, upon satisfaction of the recommended stipulation.

Waterbody Crossings and Structures

The Waterbody Crossings and Structures Rule is triggered whenever a structure is placed in the bed or bank of a waterbody. The project includes replacement of two outfalls on the bank of the lake, which triggers the rule.

The applicant is proposing the replacement of two failing outfalls that have scoured the bed and bank of the lake. The northern outfall currently enters the lake at an angle, which makes scour more likely. That outfall will be replaced to outlet perpendicularly to the bank and a hydrodynamic separator will be added in-line to remove particulates. The eastern outfall is made up of two pipes that currently outlet separately to the lake. The pipes accumulate sediment quickly and require frequent jetting to maintain capacity and reduce sedimentation to the lake. The applicant is proposing connecting both pipes to a single box culvert, instead of separate



flared end sections, to allow access for maintenance. The pipes are located too close together to allow separate manholes to be used for access, so a combined structure was proposed.

Per section 3(a) of the rule, the use of the bed or bank shall meet a demonstrated public benefit. The applicant has stated that the replacement of the outfalls will support better water quality and an improved aesthetic by repairing and preventing scour. Staff and the District Engineer concur with the Applicant’s findings that the proposed replacements will reduce scour and provide water quality improvements. The Applicant has met this criteria of the rule.

Per section 3(b) of the rule, use of the bed or bank shall retain adequate hydraulic capacity, and may not result in upstream or downstream increases in flood stage for crossings involving watercourses. The flows through each of the outfalls are constrained upstream and the applicant has provided calculations – summarized in the table below – demonstrating that the flow rate will be maintained and that the velocity will decrease at each of the outfalls. Based on this analysis, staff and the District Engineer have determined that the Applicant has met this criteria of the rule.

Site	Outlet Size/Diameter		Flow Rate (cfs)		Velocity (ft/s)	
	Existing	Proposed	Existing	Proposed	Existing	Proposed
Northern Outfall	21”	30”	15.9	15.9	7.4	5.2
Eastern Outfall	2 x 36”	10’x4’	47.2	47.2	7.5	6.1

Table 3: Existing & Proposed Outfall Comparison

Per section 3(c) of the rule, the use of the bed or bank shall retain adequate navigational capacity pursuant to any requirements of the waterbody’s classification by the District. Stormwater outfalls are not used for navigation, therefore the requirement does not apply.

Section 3(d) of the rule requires waterbody crossings and structures to preserve wildlife passage. As buried utilities, the outfalls do not in existing or proposed form impact wildlife passage. Therefore the section of the rule has been met.

Per section 3(e) of the rule, use of the bed or bank shall not adversely affect water quality. The outfalls are designed to reduce scour and erosion of the bank and the northern outfall replacement involves addition of a hydrodynamic separator which will remove pollutants prior to discharge. Furthermore, the applicant has proposed permanent energy dissipation, through vegetated riprap, which will prevent future scour from displacing sediment. Based on this analysis, staff and the District Engineer have determined that the Applicant has met this criteria of the rule.

Per section 3(f) of the rule, the use of the bed or bank shall represent the “minimal impact” solution to a specific need with respect to all other reasonable alternatives, including, but not limited to vegetation or bioengineering for bank stabilization, structural stabilization, acquisition of additional easements, or installation of upstream control to manage stream flow. For both outfalls, the applicant considered the no-build scenario but determined that the outfalls in their



current state would continue to erode the banks. The applicant also considered reinstalling energy dissipation around the outfalls but determined that the cause of erosion would not be rectified and future disturbance would be needed. Installation of a headwall on the box culvert was considered instead of an end section. The headwall would have required greater disturbance of the shoreline and would reduce the natural appearance of the shoreline. Staff finds that the proposed outfalls are the minimally impactful solutions.

Section 3(g) of the rule is not applicable, as no bored utility lines are proposed underneath the bed or bank of a watercourse.

Section 3(h) of the rule is not applicable, as no installation, modification, or excavation of sanitary sewer beneath a waterbody is proposed as a component of this project.

In summary, the proposed outfalls have been determined by staff and the District Engineer to meet the criteria of the Waterbody Crossings and Structures rule.

Per section 6 of the rule, maintenance requirements for the crossings will be met through the existing programmatic maintenance agreement between the City of Edina and the District.

In summary, based on the analysis of staff and the District Engineer provided above, the applicant has met all the applicable criteria of the Waterbody Crossings and Structures rule.

Exception

The Variance and Exception Rule allows the Board of Managers to grant exceptions from a provision of the rules on a determination that the proposed application will achieve a greater degree of water resource protection than strict compliance with the provision. The Applicant has requested an exception from the buffer provision of the Wetland Protection Rule.

The applicant is not meeting the required buffer width or area. The proposed project will restore 4,800 linear feet of shoreline, 4,500 feet of which has fringe wetland present. The required buffer area on the wetland is 6.9 acres, when reducing the required buffer width to 67 feet to account for beneficial soils and slopes, as allowed under 6(b) of the Wetland Protection Rule. The upland buffer provided totals 2.5 acres. The total acreage of vegetative restoration is 4.5 (when including the wetland fringe and emergent vegetation), which will be providing equivalent functions and values to a native wetland buffer. The width of the buffer ranges from 0 feet to 60 feet. The narrowest combination of upland buffer and shoreline vegetation is 8 feet. As this project area is parkland and a project goal is to provide intentional recreational access to the water, the design of the restoration takes into consideration the location of the trails around the lake and existing recreation areas. The applicant stated in the Exception request form that upland buffer has been included in all areas where buffer would not unreasonably impede upon the recreational opportunities in the park.

The wetland buffer provision of the Wetland Protection Rule is intended to provide water quality treatment to stormwater prior to entering a waterbody and to provide habitat adjacent to waterbodies. The applicant has provided a plan for a restoration project with the goals of water



quality treatment and habitat restoration. The project involves establishment of native vegetation in areas that are either vegetated with invasive species, maintained as turf, or not vegetated due to erosion.² In those areas water quality and habitat will be improved by the work in the buffer area, as well as the shoreline wetland fringe, and the emergent zone. Native vegetation provides greater filtration of stormwater and a greater reduction in erosion than the existing vegetation and provides a more diverse habitat than the existing vegetation.

The project design of the upland buffer, wetland fringe, and emergent zone exceeds what would be required by the wetland protection rule. Where feasible, diverse native vegetation will extend 50 feet into adjacent upland areas. Conversely, the applicant could meet the rule requirements by ceasing to mow or fertilize the existing mixture of invasive species and low maintenance turf in area within 67 feet of the wetland edge, since the disturbance to the buffer is proposed for the purpose of native vegetation establishment, and would not otherwise occur. Instead, the applicant has applied for an exception from the rule on the basis that the vegetative restoration of the three zones provides a greater degree of natural resource protection than establishment of a buffer that utilizes the existing poor quality vegetation as allowed by the rule.

The applicant has also provided additional water quality treatment through the improvements to the outfalls, which currently contribute sediment and phosphorus loading to the lake, which are not required to meet other regulatory requirements. The northern outfall in particular provides water quality treatment through the use of a hydrodynamic separator to remove sediment from the stormwater discharge. The hydrodynamic separator will provide 100% removal of floatables and 80% removal of total suspended solids for the pipeshed of the outfall. Due to the large grass area upgradient of the wetland and wetland buffer, sediment deposition to the lake from stormwater entering the lake overland is minimal. The hydrodynamic separator will provide sediment removal from and outfall receiving water from streets with more substantial sediment flow. Additionally, the repair of erosion on the shoreline, and the stabilization achieved through restoration of the riparian zone will reduce the concentration of suspended sediments, which are currently released from the shoreline to the lake as the shoreline continues to erode. The establishment of vegetation in the emergent zone provides nutrient uptake and provides shelter for aquatic animals, which is not currently present in the lake. Amphibians and other semi-aquatic species utilize different vegetative communities throughout their life cycle and throughout the seasons, and are therefore provided a better continuum of habitat within and around the water resource. By combining the three treatments, a greater habitat benefit is provided than by establishment of the same acreage of any one treatment.

The applicant indicates in the request that the project balances achieving the water quality improvements, restoration of ecological integrity and promoting and enhancing the value of water resources, through maintenance of a valuable recreational resource around the lake, which are three of the four goals central to the mission of the MCWD. Staff concurs with the analysis and technical justifications provided by the applicant.

² The rule requires establishment of native species in the areas not vegetated due to erosion, but in the rest of the buffer area, the existing vegetation can remain unless disturbed. The eroded areas make up approximately 100 square feet of the buffer.

**Summary:**

The Minneapolis Parks and Recreation Board has applied for a Minnehaha Creek Watershed District permit under the Erosion Control, Floodplain Alteration, Wetland Protection, Shoreline and Streambank Stabilization, Waterbody Crossings and Structures, and Variance and Exception rules for a restoration of the shoreline of Lake Nokomis. The proposed project meets the applicable requirements under the applicable rules, upon satisfaction of the recommended conditions and approval of the exception by the Board of Managers. Staff recommends approval of the permit with the conditions listed.

Attachments:

1. Water Resources Application Form
2. Combined Joint Notification Form
3. Exception Request
4. Site Plans
5. Boundary and Type NOD

WATER RESOURCE PERMIT APPLICATION FORM

Use this form to notify/apply to the Minnehaha Creek Watershed District (MCWD) of a proposed project or work which may fall within their jurisdiction. Fill out this form completely and submit with your site plan, maps, etc. to the MCWD at:
15320 Minnetonka Blvd. Minnetonka, MN 55345.

Keep a copy for your records.

YOU MUST OBTAIN ALL REQUIRED AUTHORIZATIONS BEFORE BEGINNING WORK.

1. Name of each property owner: Minneapolis Park and Recreation Board

Mailing Address: 2117 West River Road City: Minneapolis State: MN Zip: 55411

Email Address: JDuesman@minneapolisparcs.org Phone: 612-230-6471 Fax: _____

2. Property Owner Representative Information (not required) (licensed contractor, architect, engineer, etc...)

Business Name: Applied Ecological Services, Inc. Representative Name: Douglas Mensing

Business Address: 21938 Mushtown Rd City: Prior Lake State: MN Zip: 55372

Email Address: dougm@appliedeco.com Phone: 612-202-2252 Fax: 952-447-1920

3. Project Address: 5001 W Lake Nokomis Pkwy City: Minneapolis

State: MN Zip: 55417 Qtr Section(s): all Section(s): 13 Township(s): 28 Range(s): 24

Lot: NA Block: NA Subdivision: NA PID: multiple

4. Size of project parcel (square feet or acres): 98 acres (multiple parcels, not including lake)

Area of disturbance (square feet): 2,028 (not including veg. resto.) Volume of excavation/fill (cubic yards): 13.3 / 13.3

Area of existing impervious surface: 608 sf Area of proposed impervious surface: 0 sf

Length of shoreline affected (feet): 4,800 Waterbody (& bay if applicable): Lake Nokomis

5. Type of permit being applied for (Check all that apply):

- | | |
|--|--|
| <input checked="" type="checkbox"/> EROSION CONTROL | <input checked="" type="checkbox"/> WATERBODY CROSSINGS/STRUCTURES |
| <input checked="" type="checkbox"/> FLOODPLAIN ALTERATION | <input type="checkbox"/> STORMWATER MANAGEMENT |
| <input type="checkbox"/> WETLAND PROTECTION | <input type="checkbox"/> APPROPRIATIONS |
| <input type="checkbox"/> DREDGING | <input type="checkbox"/> ILLICIT DISCHARGE |
| <input checked="" type="checkbox"/> SHORELINE/STREAMBANK STABILIZATION | |

6. Project purpose (Check all that apply):

- | | |
|--|--|
| <input type="checkbox"/> SINGLE FAMILY HOME | <input type="checkbox"/> MULTI FAMILY RESIDENTIAL (apartments) |
| <input type="checkbox"/> ROAD CONSTRUCTION | <input type="checkbox"/> COMMERCIAL or INSTITUTIONAL |
| <input checked="" type="checkbox"/> UTILITIES | <input type="checkbox"/> SUBDIVISIONS (include number of lots) |
| <input type="checkbox"/> DREDGING | <input type="checkbox"/> LANDSCAPING (pools, berms, etc.) |
| <input checked="" type="checkbox"/> SHORELINE/STREAMBANK STABILIZATION | <input type="checkbox"/> OTHER (DESCRIBE): |

7. NPDES/SDS General Stormwater Permit Number (if applicable): _____

8. Waterbody receiving runoff from site: Lake Nokomis

9. Project Timeline: Start Date: 4/1/2019 Completion Date: 12/31/2020

Permits have been applied for: City _____ County _____ MN Pollution Control Agency _____ DNR _____ COE _____

Permits have been received: City _____ County _____ MN Pollution Control Agency _____ DNR _____ COE _____

By signing below, I hereby request a permit to authorize the activities described herein. I certify that I am familiar with MCWD Rules and that the proposed activity will be conducted in compliance with these Rules. I am familiar with the information contained in this application and, to the best of my knowledge and belief, all information is true, complete and accurate. I understand that proceeding with work before all required authorizations are obtained may be subject to federal, state and/or local administrative, civil and/or criminal penalties.

Signature of Each Property Owner

10/21/2019
Date

**Minnehaha Creek Watershed District
 Water Resource Permit Application Form – Supplemental Information
 Lake Nokomis Shoreline Enhancement Project (WCA Application Number W17-42)**

Supporting Narrative:

- Stabilization 7.c.6 – The designer will stake the location of the shoreline treatments in the field before construction and will inspect the progress regularly.

- Stabilization 7.g.1. – Riprap will only be applied at the eastern “point” along the shoreline and at stormwater outfalls, as shown in the standard plates and plan details to protect the area around the drainage pipe/box culvert and the area directly below it. The “point” is categorized as “High” on the Erosion Intensity Scoresheet.

- Stabilization 7.g.2. – Riprap was minimized by applying TRM with native vegetation along other eroded areas along the shoreline. The riprapped area on the “point” was minimized after a field visit which confirmed that only the north facing slopes were without vegetative cover. The top 2.5 feet of the riprap will have 6” of topsoil placed with deep rooted native vegetation to minimize the appearance of riprap from shore.

Waterbody Structures

1. Demonstration of public benefit – See Joint Application Form, Part Three
2. Retention of adequate hydraulic capacity – Two storm sewer outfalls will be improved with this project. One is currently a 21” RCP draining to an outlet control structure that is angled at adjacent shoreline such that it is creating a scourhole and the other site has dual 36” RCPs that extend 30’ into the lake and are falling apart. The goal of the improvements is to reduce erosion and scour at the outfalls by properly directing the outfalls, providing permanent erosion control, and increasing the outlet size. To do design this, we do not need to model the outfalls using hydraulic models, only to use the Open Channel equation. The upstream capacity (Q) is restricted by the size of the pipe system and tends to be 10 year design or less. As the flow area within the final section of pipe are increased to 30” and 10’ x 4’, respectively, the velocity decreases. The tailwater elevation of the lake will also not change with this project. Therefore hydraulic capacity of the storm sewer system is not changed with the modifications of the outfalls.

3.

	Outlet Description		Flow Rate		Velocity	
	Existing	Proposed	Existing	Proposed	Existing	Proposed
			cfs	cfs	fps	fps
Site #7	21"	30"	15.9	15.9	7.4	5.2
Site #16	2-36"	10'x4'	47.2	47.2	7.5	6.1

3. Represent minimal impact solution – See Joint Application Form, Part Three

Volume of Excavation and Fill - See Joint Application Form, Attachment 4

Joint Application Form for Activities Affecting Water Resources in Minnesota

This joint application form is the accepted means for initiating review of proposals that may affect a water resource (wetland, tributary, lake, etc.) in the State of Minnesota under state and federal regulatory programs. Applicants for Minnesota Department of Natural Resources (DNR) Public Waters permits **MUST** use the MPARS online permitting system for submitting applications to the DNR. Applicants can use the information entered into MPARS to substitute for completing parts of this joint application form (see the paragraph on MPARS at the end of the joint application form instructions for additional information). This form is only applicable to the water resource aspects of proposed projects under state and federal regulatory programs; other local applications and approvals may be required. Depending on the nature of the project and the location and type of water resources impacted, multiple authorizations may be required as different regulatory programs have different types of jurisdiction over different types of resources.

Regulatory Review Structure

Federal

The St. Paul District of the U.S. Army Corps of Engineers (Corps) is the federal agency that regulates discharges of dredged or fill material into waters of the United States (wetlands, tributaries, lakes, etc.) under Section 404 of the Clean Water Act (CWA) and regulates work in navigable waters under Section 10 of the Rivers and Harbors Act. Applications are assigned to Corps project managers who are responsible for implementing the Corps regulatory program within a particular geographic area.

State

There are three state regulatory programs that regulate activities affecting water resources. The Wetland Conservation Act (WCA) regulates most activities affecting wetlands. It is administered by local government units (LGUs) which can be counties, townships, cities, watershed districts, watershed management organizations or state agencies (on state-owned land). The Minnesota DNR Division of Ecological and Water Resources issues permits for work in specially-designated public waters via the Public Waters Work Permit Program (DNR Public Waters Permits). The Minnesota Pollution Control Agency (MPCA) under Section 401 of the Clean Water Act certifies that discharges of dredged or fill material authorized by a federal permit or license comply with state water quality standards. One or more of these regulatory programs may be applicable to any one project.

Required Information

Prior to submitting an application, applicants are **strongly encouraged** to seek input from the Corps Project Manager and LGU staff to identify regulatory issues and required application materials for their proposed project. Project proponents can request a pre-application consultation with the Corps and LGU to discuss their proposed project by providing the information required in Sections 1 through 5 of this joint application form to facilitate a meaningful discussion about their project. Many LGUs provide a venue (such as regularly scheduled technical evaluation panel meetings) for potential applicants to discuss their projects with multiple agencies prior to submitting an application. Contact information is provided below.

The following bullets outline the information generally required for several common types of determinations/authorizations.

- For delineation approvals and/or jurisdictional determinations, submit Parts 1, 2 and 5, and Attachment A.
- For activities involving CWA/WCA exemptions, WCA no-loss determinations, and activities not requiring mitigation, submit Parts 1 through 5, and Attachment B.
- For activities requiring compensatory mitigation/replacement plan, submit Parts 1 thru 5, and Attachments C and D.
- For local road authority activities that qualify for the state's local road wetland replacement program, submit Parts 1 through 5, and Attachments C, D (if applicable), and E to both the Corps and the LGU.

Submission Instructions

Send the completed joint application form and all required attachments to:

U.S Army Corps of Engineers. Applications may be sent directly to the appropriate Corps Office. For a current listing of areas of responsibilities and contact information, visit the St. Paul District's website at:

<http://www.mvp.usace.army.mil/Missions/Regulatory.aspx> and select "Minnesota" from the contact Information box.

Alternatively, applications may be sent directly to the St. Paul District Headquarters and the Corps will forward them to the appropriate field office.

Section 401 Water Quality Certification: Applicants do not need to submit the joint application form to the MPCA unless specifically requested. The MPCA will request a copy of the completed joint application form directly from an applicant when they determine an individual 401 water quality certification is required for a proposed project.

Wetland Conservation Act Local Government Unit: Send to the appropriate Local Government Unit. If necessary, contact your county Soil and Water Conservation District (SWCD) office or visit the Board of Water and Soil Resources (BWSR) web site (www.bwsr.state.mn.us) to determine the appropriate LGU.

DNR Public Waters Permitting: In 2014 the DNR will begin using the Minnesota DNR Permitting and Reporting System (MPARS) for submission of Public Waters permit applications (<https://webapps11.dnr.state.mn.us/mpars/public/authentication/login>).

Applicants for Public Waters permits **MUST** use the MPARS online permitting system for submitting applications to the DNR. To avoid duplication and to streamline the application process among the various resource agencies, applicants can use the information entered into MPARS to substitute for completing parts of this joint application form. The MPARS print/save function will provide the applicant with a copy of the Public Waters permit application which, at a minimum, will satisfy Parts one and two of this joint application. For certain types of activities, the MPARS application may also provide all of the necessary information required under Parts three and four of the joint application. However, it is the responsibility of the Applicant to make sure that the joint application contains all of the required information, including identification of all aquatic resources impacted by the project (see Part four of the joint application). After confirming that the MPARS application contains all of the required information in Parts one and two the Applicant may attach a copy to the joint application and fill in any missing information in the remainder of the joint application.

PART ONE: Applicant Information

If applicant is an entity (company, government entity, partnership, etc.), an authorized contact person must be identified. If the applicant is using an agent (consultant, lawyer, or other third party) and has authorized them to act on their behalf, the agent's contact information must also be provided.

Applicant/Landowner Name: Minneapolis Park and Recreation Board

Mailing Address: 2117 West River Road, Minneapolis, MN 55411

Phone: 612-230-6400

E-mail Address: NA

Authorized Contact (do not complete if same as above): Jon Duesman

Mailing Address: 2117 West River Road, Minneapolis, MN 55411

Phone: 612-230-6471

E-mail Address: JDuesman@minneapolisparcs.org

Agent Name: Douglas Mensing

Mailing Address: 21938 Mushtown Rd, Prior Lake, MN 55372

Phone: 612-202-2252

E-mail Address: dougm@appliedeco.com

PART TWO: Site Location Information

County: Hennepin

City/Township: Minneapolis

Parcel ID and/or Address: 5001 W Lake Nokomis Pkwy, Minneapolis, MN 55417

Legal Description (Section, Township, Range): S13, T28, R24

Lat/Long (decimal degrees): 44.914/-93.236

Attach a map showing the location of the site in relation to local streets, roads, highways. See plans.

Approximate size of site (acres) or if a linear project, length (feet): 4.6 acres; approximately 4,800 ft of shoreline

If you know that your proposal will require an individual Permit from the U.S. Army Corps of Engineers, you must provide the names and addresses of all property owners adjacent to the project site. This information may be provided by attaching a list to your application or by using block 25 of the Application for Department of the Army permit which can be obtained at:

http://www.mvp.usace.army.mil/Portals/57/docs/regulatory/RegulatoryDocs/engform_4345_2012oct.pdf

PART THREE: General Project/Site Information

If this application is related to a delineation approval, exemption determination, jurisdictional determination, or other correspondence submitted *prior to* this application then describe that here and provide the Corps of Engineers project number.

Describe the project that is being proposed, the project purpose and need, and schedule for implementation and completion. The project description must fully describe the nature and scope of the proposed activity including a description of all project elements that effect aquatic resources (wetland, lake, tributary, etc.) and must also include plans and cross section or profile drawings showing the location, character, and dimensions of all proposed activities and aquatic resource impacts.

Overview: The applicant is pursuing a Nationwide Permit 27 (Aquatic Habitat Restoration, Enhancement, and Establishment Activities) and a Utility Regional General Permit from the U.S. Army Corps of Engineers (Corps), and an "Exemption for Utilities" and a "No-Loss Determination" from the Minnehaha Creek Watershed District (MCWD, the Local Governmental Unit (LGU) for the site, which also has Public Waters permitting authority via an

agreement with the Minnesota Department of Natural Resources, MnDNR). No mitigation is proposed, since the project is: 1) a voluntary ecological restoration project that will result in net increases in upland habitat and aquatic resource functions and services, and 2) a stormwater infrastructure repair project, which has been integrated into the shoreline enhancement project. These projects will not result in the loss of Waters of the U.S., existing erosion areas will be repaired and stabilized, and riprap will be placed only where necessary to stabilize the shoreline.

Previous Work/Approvals: A pre-application consultation and site review was convened on September 11, 2017; in attendance were representatives of the Corps, MCWD, MnDNR, City of Minneapolis, Minneapolis Park and Recreation Board (MPRB), and the design team, consisting of Applied Ecological Services, Inc. (AES) and SRF Consulting Group(SRF). A wetland delineation of the project area was conducted by AES in September 2017. A wetland boundary or type approval was issued by the MCWD/LGU on December 6, 2017. The project number under the Wetland Conservation Act is Application Number W17-42, and the Corps Regulatory File No. is 2017-03022-MMJ.

Purpose and Need: Data reviewed and considered during the design of this project include but are not limited to:

- History of the Lake Nokomis area (historical maps and records)
- Public waters and other wetlands mapping (National Wetlands Inventory update; MCWD Functional Wetland Assessment)
- Historical and current water level
- Lake water quality
- Fish survey
- MnDNR Natural Heritage Database rare natural features
- Lake bathymetry
- Survey of shoreline, trees, and stormwater utilities
- Nokomis-Hiawatha Regional Park Master Plan (2015)
- Prevailing winds

Historically, Lake Nokomis was a large (~300 acre) wetland. In the early 1900s a portion of the lake was dredged to make the 200-acre lake we know today. Spoils from the dredging were spread along the shoreline creating flat parkland, including the majority of the project area.

Today, Lake Nokomis is a highly valued park within the nationally-recognized Minneapolis park system. Popular uses include walking, biking, fishing, swimming, and boating. The Nokomis-Hiawatha Regional Park Master Plan (2015) identified issues with Lake Nokomis, including poor water clarity and quality and a desire to increase and improve the park's natural setting and landscape (including increased and improved upland buffer, shoreline, and emergent vegetation).

The Lake Nokomis Shoreline Enhancement project includes portions of the west, north, and east shoreline, generally extending from the existing bituminous pedestrian trail towards the shoreline; in areas where emergent plantings are proposed to enhance the littoral zone, restoration will occur to a depth of approximately two feet. Areas containing intact historic Works Progress Administration (WPA) stone walls, recreational beaches, and concrete structures were not included in the project area.

The project area was divided into three zones:

- The **Upland Buffer Zone** (approximately 2.49 acres) extends from the existing pedestrian trail's "clear zone" (extending 4 feet from the bituminous trail edge) to the edge of the delineated shoreline wetland. This zone is currently dominated by mowed turf grass (e.g., Kentucky bluegrass, *Poa pratensis*) with scattered planted trees, creating a parkland landscape (see Attachment 1, Photograph 1).
- The **Shoreline Zone** (approximately 1.22 acre) extends from the edge of the delineated shoreline wetland to the water's edge (assuming average water level). For the majority of the shoreline length, this zone is a narrow strip of sloped land with trees and shrubs that create dense shade (see Attachment 1, Photograph 2). However, the majority of this zone's acreage is found on the east side of the lake where two wider strips of wetland exist, dominated by invasive narrow-leaved cattail (*Typha angustifolia*), reed canary grass (*Phalaris arundinacea*), and sandbar willow (*Salix exigua*); see Attachment 1, Photograph 3.

- The **Emergent Zone** (approximately 0.74 acre) extends from the average water line to a depth of approximately two feet (part of the littoral zone). This zone is characterized by its general lack of vegetation (see Attachment 1, Photograph 4).

Because the majority of the project area is not wetland, and the majority of the shoreline wetland is a very narrow linear feature (unlike a typical wetland “basin”), a formal Minnesota Routine Assessment Method (MnRAM) was not completed. Field characterization of vegetation communities identified dominance by non-native and invasive herbaceous species (e.g., Kentucky bluegrass, reed canary grass), with invasive common buckthorn (*Rhamnus cathartica*) and native sandbar willow present in portions of the Shoreline Zone. Vegetation is essentially absent from the project’s littoral zone. Using MnRAM’s Vegetative Diversity/Integrity assessment, the project area’s wetlands (i.e., Shoreline Zone and Emergent Zone) score “Low Quality” due to the abundance of invasive species (mostly narrow-leaved cattail and reed canary grass) and low diversity and cover by native species. A few very small patches of native vegetation (believed to be remnants of previous restoration plantings) were observed along the shoreline; these patches contained prairie cordgrass (*Spartina pectinata*), green bulrush (*Scirpus atrovirens*), nodding beggartick (*Bidens cernua*), American water horehound (*Lycopus americanus*), and sedges (*Carex* spp).

Portions of the project shoreline are experiencing erosion. This erosion results in the loss of parkland, sedimentation in the lake (increasing turbidity and reducing littoral habitat quality), and release of nutrients into the water (increasing algal growth and decreased water quality). The most severe erosion is located on the project’s east shoreline, known as the “Point” (see plan Sheet 17 and Attachment 1, Photograph 5). This erosion is caused by wave action, steep underwater slopes, a steep bank, and lack of deep-rooted vegetation. Limited erosion is also occurring south of the west beach (see plan Sheet 4 and Attachment 1, Photograph 6). This erosion is caused by bare soil in the upland, lack of deep-rooted vegetation, and an existing bituminous path that sheds water over the bank. Additionally, erosion is occurring at two stormwater utility outfalls. Erosion at the north stormwater outfall (see plan Sheet 8 and Attachment 1, Photograph 7) is caused by stormwater discharges from the angled outfall located inland from the lake’s natural shoreline (resulting in an eroded plunge pool) and wave action around the outfall. Erosion at the east stormwater outfall (see plan Sheet 16 and Attachment 1, Photograph 8) is caused by prevailing winds and associated wave action, which deflects off the collapsing concrete pipes and has eroded the shoreline to the south. The exposed pipes now extend nearly 30 feet into the lake, and pipe segment joints have broken due to significant settling. Several small areas of minor erosion exist along the project shoreline (see plan Sheets 5 through 16 and Attachment 1, representative Photographs 9 and 10). These small areas of erosion (generally along the edge of mowed turf) are caused by foot traffic and lack of deep-rooted vegetation. An example of stabilized shoreline at Lake Nokomis exists south of the west beach, just south of the existing bituminous path erosion area (see Attachment 1, Photograph 11). Years ago, riprap boulders were installed to stabilize this eroding shoreline, and the treatment has proven successful and attractive.

In order to design appropriate shoreline stabilization treatments, the MCWD’s Erosion Intensity Scoresheet was completed for the lake’s north shoreline and east shoreline, including the Point. This assessment suggests that erosion intensity is “medium” along the lake’s north shoreline, but it is “high” along the lake’s east shoreline at the Point (Attachment 2).

Over the last two years, Lake Nokomis has experienced higher than normal water levels (see Attachment 3). This is due to a combination of precipitation patterns, changes in the watershed’s stormwater system, and management of the lake’s outlet that discharges into Minnehaha Creek.

According to the Minnesota Department of Natural Resources (MnDNR) Natural Heritage Database (2016 data), no rare natural features (including listed plants or animals) have been identified in the project area.

Historical Works Progress Administration (WPA) walls used to exist in the project area. However, most of these walls were intentionally removed decades ago, and no intact walls remain in the project area today. A separate report has been prepared by Hess Roise to address the project area’s cultural resources, which are regulated under Section 106 and the Minnesota State Historic Preservation Office (SHPO).

Proposed Conditions: The applicant proposes to replace/repair two (2) failing stormwater utility outfalls, stabilize shoreline erosion, remove invasive vegetation, and install diverse native vegetation to create an attractive and functional continuum of shoreline zones. These restored and enhanced native habitats will benefit both upland and aquatic species, including native plants and animals.

The alternatives analysis for the repair of the two (2) failing stormwater utility outfalls includes the No Build Option and two repair/restoration options for each outfall.

- North Stormwater Outfall.
 - No Build option - would result in retaining this unsightly piece of infrastructure that was poorly designed and has resulted in significant erosion of the shoreline.
 - Erosion Correction option - would leave the 1970s outfall in place and simply install riprap around the eroded bank; this option was not favorable because it did not improve water quality or fix the cause of erosion, and would have a limited life span.
 - Rebuild Option – the proposed solution includes replacing the angled pipe with a straight pipe, extending the pipe to the natural shoreline, restoring a more natural and stable shoreline, and installation of a CDS hydrodynamic separator that will improve the quality of stormwater discharged to the lake. This solution will have a longer life span than the simple riprap approach, and the public will benefit from improved aesthetics along the shoreline and improved water quality in the lake.
- East Stormwater Outfall.
 - No Build option - would result in retaining this unsightly, severely eroded and collapsing piece of infrastructure that was constructed in the 1940s; these pipes have resulted in significant erosion of the shoreline, and they are separated at their joints as the pipes are settling severely.
 - Outfall replacement with a Box Culvert and Headwall - would require construction of a headwall; this approach would require significant shoreline disturbance to install the required footings for such a structure and would be more costly.
 - Outfall replacement with a Box Culvert and End Section - the proposed solution includes replacing the damaged pipes with a concrete box culvert at the shoreline, and restoring a more natural and stable lakeshore edge. The public will benefit from improved aesthetics along the shoreline and an observation/access point on top of the box culvert, providing access/views at the shoreline and an opportunity for fishing.

Hard armoring was minimized in the design of this shoreline enhancement and stabilization project. Of the project's approximately 4,800 linear feet of shoreline, only 175 feet (3.6 percent) will be stabilized with riprap. Use of hard armoring in these select areas was justified by the MCWD's Erosion Intensity Scoresheet and the repair of the two stormwater utility outfalls. Shoreline smoothing at the two stormwater outfalls (Sheet 25) will result in a net gain of 4.4 cubic yards of floodplain storage and lake surface area will be retained. (The 4.4 cubic yards of soil will be used to repair a nearby curb cut swale (Sheet 18), which is located above the 100-yr floodplain elevation). No loss of Waters of the U.S. will occur. See Attachment 4 for volume of excavation and fill calculations and assumptions.

Additional project tasks and elements include:

- Installation of erosion control measures, including 2,732 linear feet of wave break/fish exclusion barrier (in Emergent Zone planting areas), 315 linear feet of flotation silt curtain (in three locations where shoreline will be re-graded), and 500 linear feet of wood chip filter socks (in locations where minor soil knock-down/smoothing will occur).
- Removal of turf grass and invasive woody and herbaceous plant species from Upland Buffer and Shoreline Zone.
- Removal of 530 square feet of bituminous trail (south of west beach).
- Re-grading of eroded shoreline areas to provide a more natural shoreline edge and a more stable and gradual land-to-water transition. 200 square yards of turf reinforcement mat (TRM), 200 square yards of degradable erosion control blanket installed on top of the TRM, and an additional 145 square yards of erosion control blanket will be installed to stabilize areas with existing or potential soil erosion. Soil (fill) will not be imported to the site, except 2.5 cubic yards of topsoil for restoration where the existing bituminous path will be removed at Repair Site 1. Aside from the Point and stormwater outfall repairs, earthwork will be limited to minor grading using existing soil and resulting in no wetland fill or loss of

floodplain storage. Riprap is not counted as fill for this project because it is being used in locations where soil has eroded from the original shoreline.

- Installation of riprap (boulders) along the Point where the shoreline is experiencing significant erosion (see Attachment 1, Photograph 11 for riprap treatment similar to what is proposed for this project). The justification for using riprap was determined by completing the MCWD Erosion Intensity Scoresheet, which rated the Point as “High” erosion intensity (see Attachment 2). Riprap size was determined using FHWA Hydraulic Toolbox Wave Attack Analysis. The riprap’s influence on floodplain storage has been minimized while still providing the required stability (Sheet 22, Detail 1).
- Shoreline grading, riprap placement, and other construction activities within Lake Nokomis will not occur during the MnDNR’s fish spawning dates for lakes (April 1 through June 30).
- Installation of context-sensitive native seed and live plants in the 2.49-acre Upland Buffer, 1.22-acre Shoreline Buffer, and 0.74-acre Emergent Zone.
- Soil will not be tilled during restoration activities. Turf grass and herbaceous invasive species will be treated with appropriate herbicide, and native seed will be installed either by no-till seed drill and/or raking seed down to the soil surface. This approach will retain soil-anchoring roots and prevent erosion.
- Installation of 4,950 linear feet of protective fencing around Upland Buffer and 2,732 linear feet of wave break/fish exclusion fencing around Shoreline Zone plantings.
- Establishment of resilient access points for people to reach the lakeshore at designated locations.
- Regrading and stabilization of a nearby curb cut swale (south of the lake, above the 100-yr floodplain, Sheet 18).
- Vegetation management and monitoring during the initial establishment period (i.e., through end of 2020). After that, the MPRB is committed to long-term management of the restoration plantings and has operational funds dedicated for this maintenance.
- Development of a written management plan that prescribes specific protocols for long-term maintenance.

MnRAM’s vegetation diversity/integrity measure will improve significantly by removal of turf grass and invasive vegetation and replacement with diverse native species. Regarding other ecosystem functions addressed by MnRAM, the proposed project will:

- not affect hydrologic regimes,
- not affect floodwater storage
- improve stormwater management and water quality (through installation of a stormwater treatment structure and dense, deep-rooted, native buffer plantings along the lakeshore),
- protect the shoreline through erosion correction, stabilization, and native plantings (along shoreline and in littoral zone),
- improve fish and wildlife habitat through installation of diverse native vegetation in uplands, shoreline wetlands, and the littoral zone,
- improve aesthetics through context-sensitive native plantings,
- provide opportunities for education (e.g., interpretive signage regarding shoreline enhancement project),
- not compromise recreation or cultural values,
- not affect commercial uses, and
- not affect groundwater interaction.

The proposed project will result in the replacement/repair of two failing stormwater utility outfalls; work in these areas falls under the Exemption for Utilities (see Attachment B). The proposed project will also result in “no-loss” of wetland quantity, quality, or biological diversity (see Attachment B – No-Loss Applicability). The comparison of the project area’s existing and proposed conditions indicates a significant increase in ecological functions and services of the lake’s Upland Buffer Zone, Shoreline Zone, and Emergent Zone. The proposed project will result in a diverse, native lakeshore buffer, stable shoreline, and native-vegetated littoral zone, similar to restored and naturalized portions of Lake of the Isles shoreline in Minneapolis (a similar ecological reference site).

Restoration/enhancement actions and native plantings will not obscure views of the lake and will allow people to access the shoreline in designated locations.

Schedule: The proposed shoreline enhancement and stormwater outlet repair schedule follows:

- **Spring/Summer 2019:** Conduct site preparation (herbicide turf and invasive vegetation).
- **Spring/Summer 2019.** Cut and remove invasive woody vegetation, thin aggressive/dense native woody vegetation, and prune select trees.
- **Summer 2019:** Conduct soil knock-down/smoothing of small erosion areas.
- **Summer 2019 (after June 30):** Install riprap and other stabilization at Point.
- **Summer 2019 (after June 30):** Replace two (2) stormwater outfalls.
- **Summer 2019:** Install native seed and live native plantings in all zones.
- **Late Summer 2019 through end of 2020:** Conduct monitoring and initial management.
- **2021 and Beyond:** Long-term maintenance of native plantings.

Monitoring and Maintenance Plan: The following tasks will be conducted to ensure the project is constructed and managed properly during establishment and over the course of long-term maintenance.

- Routine Erosion Control Inspections will be conducted during construction per the Stormwater Pollution Prevention Plan (SWPPP) – see Sheets 33-35 of plan set. Inspections will be conducted:
 - Once every seven days during active construction, and
 - Within 24 hours of a half inch or more precipitation.
- Construction Oversight will be conducted throughout initial construction/implementation, including installation of erosion control products, vegetation removal/treatment, seeding and planting, grading, and placement of riprap.
- Establishment Maintenance (2019-2020) will include:
 - 2019 – one to two spot herbicide treatments; two restoration mowing, and
 - 2020 – one to two spot herbicide treatments; one restoration mowing; one foliar herbicide treatment of invasive woody vegetation.
- Long-Term Maintenance (2021 and beyond) will include:
 - Annual walkabout to determine maintenance needs, and
 - Targeted spot herbicide/mowing as and where warranted.

Performance Standards: Performance standard to be applied to the wetland follow:

- 1) Within the construction limits, the combined cover of invasive cattail, reed canary grass, and other invasive vegetation shall not exceed 10% total cover within any given 100 sq ft area at any time from Summer 2019 until the end of 2020.
- 2) By late Summer 2020, total vegetation cover within Upland Buffer Zone and Shoreline Zone areas shall be no less than 80% (not including open water areas).
- 3) By late Summer 2020, Upland Buffer Zone and Shoreline Zone areas shall contain a minimum of: 20% cover by native grass/sedge species, 20% cover by native forb species, and 33% of installed species present. Emergent Zone areas shall exhibit at least 33% survivorship of installed herbaceous plants, including at least 3 planted species widely dispersed throughout the planted area.

If any performance standards are not met, Contractor shall work with Client or Client Representative to develop a remedial plan. Execution of remedial plan shall be completed by Contractor at no additional cost to Client.

Other Enclosures with this Submittal

1. 90% Construction Plans for Shoreline Stabilization, Stormwater Outfall Repairs, and Landscaping
2. Stormwater Pollution Prevention Plan (SWPPP) – see Sheets 33-35 of plan set
3. Wetland Delineation Report
4. Wetland Boundary and Type Approval (Notice of Decision)
5. U.S. Army Corps of Engineers wetland delineation letter of concurrence

Pending Submittals (to be acquired prior to construction)

1. Minnehaha Creek Watershed District (MCWD) Water Resource Permit Application
2. MCWD Erosion Control Supplemental Form
3. City of Minneapolis Sediment and Erosion Control Permit
4. National Pollutant Discharge Elimination System (NPDES) Permit
5. Minnesota Department of Natural Resources (MnDNR) Aquatic Plant Management Permit

PART FOUR: Aquatic Resource Impact¹ Summary

If your proposed project involves a direct or indirect impact to an aquatic resource (wetland, lake, tributary, etc.) identify each impact in the table below. Include all anticipated impacts, including those expected to be temporary. Attach an overhead view map, aerial photo, and/or drawing showing all of the aquatic resources in the project area and the location(s) of the proposed impacts. Label each aquatic resource on the map with a reference number or letter and identify the impacts in the following table.

Aquatic Resource ID (as noted on overhead view)	Aquatic Resource Type (wetland, lake, tributary etc.)	Type of Impact (fill, excavate, drain, or remove vegetation)	Duration of Impact Permanent (P) or Temporary (T) ¹	Size of Impact ²	Overall Size of Aquatic Resource ³	Existing Plant Community Type(s) in Impact Area ⁴	County, Major Watershed #, and Bank Service Area # of Impact Area ⁵
Lake Nokomis shoreline wetland	Wetland (between OHWL and delineated wetland boundary)	Remove vegetation, re-plant with diverse native vegetation	T(90)	1.29 ac (see Sheets 4-17)	N/A	Floodplain Forest; Fresh (Wet) Meadow	Hennepin Co., Major Watershed 20, BSA 7
Lake Nokomis shoreline wetland	Wetland (between OHWL and delineated wetland boundary)	Excavate/fill (grading to repair stormwater outfalls, smooth cut banks, install riprap and box culvert)	P	454 sf (see Sheets 8, 16 & 17)	N/A	Floodplain Forest; Fresh (Wet) Meadow	Hennepin Co., Major Watershed 20, BSA 7
Lake Nokomis	Lake (below OHWL)	Fill (install riprap at eroding shoreline and around stormwater outfalls)	P	1,574 sf (see Sheets 8, 16 & 17)	N/A	Shallow, Open Water Communities	Hennepin Co., Major Watershed 20, BSA 7

¹If impacts are temporary; enter the duration of the impacts in days next to the "T". For example, a project with a temporary access fill that would be removed after 220 days would be entered "T (220)".

²Impacts less than 0.01 acre should be reported in square feet. Impacts 0.01 acre or greater should be reported as acres and rounded to the nearest 0.01 acre. Tributary impacts must be reported in linear feet of impact and an area of impact by indicating first the linear feet of impact along the flowline of the stream followed by the area impact in parentheses). For example, a project that impacts 50 feet of a stream that is 6 feet wide would be reported as 50 ft (300 square feet).

³This is generally only applicable if you are applying for a de minimis exemption under MN Rules 8420.0420 Subp. 8, otherwise enter "N/A".

⁴Use *Wetland Plants and Plant Community Types of Minnesota and Wisconsin* 3rd Ed. as modified in MN Rules 8420.0405 Subp. 2.

⁵Refer to Major Watershed and Bank Service Area maps in MN Rules 8420.0522 Subp. 7.

If any of the above identified impacts have already occurred, identify which impacts they are and the circumstances associated with each:

¹ The term "impact" as used in this joint application form is a generic term used for disclosure purposes to identify activities that may require approval from one or more regulatory agencies. For purposes of this form it is not meant to indicate whether or not those activities may require mitigation/replacement.

PART FIVE: Applicant Signature

Check here if you are requesting a pre-application consultation with the Corps and LGU based on the information you have provided. Regulatory entities will not initiate a formal application review if this box is checked.

By signature below, I attest that the information in this application is complete and accurate. I further attest that I possess the authority to undertake the work described herein.

Signature:  Date: 10/31/2018

I hereby authorize Douglas Mensing of Applied Ecological Services, Inc. to act on my behalf as my agent in the processing of this application and to furnish, upon request, supplemental information in support of this application.

Attachment A

Request for Delineation Review, Wetland Type Determination, or Jurisdictional Determination

By submission of the enclosed wetland delineation report, I am requesting that the U.S. Army Corps of Engineers, St. Paul District (Corps) and/or the Wetland Conservation Act Local Government Unit (LGU) provide me with the following (check all that apply):

Wetland Type Confirmation

Delineation Concurrence. Concurrence with a delineation is a written notification from the Corps and a decision from the LGU concurring, not concurring, or commenting on the boundaries of the aquatic resources delineated on the property. Delineation concurrences are generally valid for five years unless site conditions change. Under this request alone, the Corps will not address the jurisdictional status of the aquatic resources on the property, only the boundaries of the resources within the review area (including wetlands, tributaries, lakes, etc.).

The applicant is requesting a wetland boundary and type modification to the Notice of Decision dated December 6, 2017. Upon further review, the Lake Nokomis "Point" (see Sheet 17 of plans) does not meet wetland criteria; the area is an eroded, unvegetated bank. Please see attached revised Wetland Delineation Map.

Preliminary Jurisdictional Determination. A preliminary jurisdictional determination (PJD) is a non-binding written indication from the Corps that waters, including wetlands, identified on a parcel may be waters of the United States. For purposes of computation of impacts and compensatory mitigation requirements, a permit decision made on the basis of a PJD will treat all waters and wetlands in the review area as if they are jurisdictional waters of the U.S. PJDs are advisory in nature and may not be appealed.

Approved Jurisdictional Determination. An approved jurisdictional determination (AJD) is an official Corps determination that jurisdictional waters of the United States are either present or absent on the property. AJDs can generally be relied upon by the affected party for five years. An AJD may be appealed through the Corps administrative appeal process.



In order for the Corps and LGU to process your request, the wetland delineation must be prepared in accordance with the 1987 Corps of Engineers Wetland Delineation Manual, any approved Regional Supplements to the 1987 Manual, and the *Guidelines for Submitting Wetland Delineations in Minnesota* (2013).

<http://www.mvp.usace.army.mil/Missions/Regulatory/DelineationJDGuidance.aspx>



**Lake Nokomis
Shoreline Enhancement**

**Wetland Delineation Map
(revised Dec. 2018)**

-  Project Boundary
-  Wetland Boundary (revised Dec. 2018)
-  Elevation Contour (2-ft interval)

Data Sources:
 - LiDAR
 - Bing basemap (aerial photo)
 AES Project Number: 17-0346
 Date: 12/17/18
 File Name: Lk Nokomis_Wet Del Map_2018-12-17



21938 Mushtown Road
 Prior Lake, MN 55372
 952-447-1919
 www.appliedeco.com

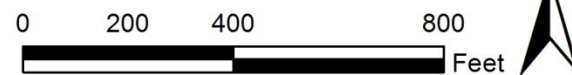

Area of revision

bing

© 2018 Microsoft Corporation © 2018 DigitalGlobe © CNES (2018) Distribution Airbus DS © 2018 HERE

Attachment B

Supporting Information for Applications Involving Exemptions, No Loss Determinations, and Activities Not Requiring Mitigation

Complete this part *if* you maintain that the identified aquatic resource impacts in Part Four do not require wetland replacement/compensatory mitigation OR *if* you are seeking verification that the proposed water resource impacts are either exempt from replacement or are not under CWA/WCA jurisdiction.

Identify the specific exemption or no-loss provision for which you believe your project or site qualifies:

Exemption for Utilities (MN Rule Chapter 8420.0420, Subpart 4 and Subpart 6)

The proposed shoreline enhancement project includes repair to two (2) existing stormwater utility outfalls. These outfalls are failing and contributing to shoreline erosion. The proposed project would replace failing infrastructure and restore, smooth, and stabilize these shoreline areas using appropriate outfall structures, riprap, and native vegetation.

No-Loss Applicability (MN Rule Chapter 8420.0415, No-Loss Criteria D)

The proposed shoreline enhancement project has been designed as a “no-loss”, “self-mitigating” project. The project area’s existing conditions are characterized by non-native and invasive vegetation (dominating the ground layer and present in the shrub layer), sections of shoreline erosion (some severe), two failing stormwater outfalls, and an absence of emergent vegetation. The proposed project will not result in the loss of wetland quantity, quality, or biological diversity.

Rather, the project will:

- 1) retain existing wetland acreage;
- 2) stabilize currently eroding sections of shoreline,
- 3) enhance the biological integrity of those acres through removal of invasive vegetation;
- 4) revegetate the project area with a diversity of native wetland and upland species;
- 5) provide upland and wetland habitat diversification and enhancement (including pollinator habitat);
- 6) replace/repair failing stormwater outfalls (eliminating current erosion), and
- 7) provide ecological monitoring and long-term maintenance.

Provide a detailed explanation of how your project or site qualifies for the above. Be specific and provide and refer to attachments and exhibits that support your contention. Applicants should refer to rules (e.g. WCA rules), guidance documents (e.g. BWSR guidance, Corps guidance letters/public notices), and permit conditions (e.g. Corps General Permit conditions) to determine the necessary information to support the application. Applicants are strongly encouraged to contact the WCA LGU and Corps Project Manager prior to submitting an application if they are unsure of what type of information to provide:

Technical Evaluation Panel Concurrence:

Project Name and/or Number: Lake Nokomis Shoreline Enhancement

TEP member:

Representing:

Concur with road authority's determination of qualification for the local road wetland replacement program? Yes No

Signature: _____

Date:

TEP member:

Representing:

Concur with road authority's determination of qualification for the local road wetland replacement program? Yes No

Signature: _____

Date:

TEP member:

Representing:

Concur with road authority's determination of qualification for the local road wetland replacement program? Yes No

Signature: _____

Date:

TEP member:

Representing:

Concur with road authority's determination of qualification for the local road wetland replacement program? Yes No

Signature: _____

Date:

Upon approval and signature by the TEP, application must be sent to: **Wetland Bank Administration
Minnesota Board of Water & Soil Resources
520 Lafayette Road North
Saint Paul, MN 55155**

Attachment 1 Site Photographs

Photo 1. Existing Conditions - Upland Buffer Zone (dominated by turf grass and planted trees).



Photo 2. Existing Conditions – Shoreline Zone (narrow strip of trees and shrubs along lakeshore).



Photo 3. Existing Conditions – Shoreline Zone (with invasive reed canary grass and cattails).



Photo 4. Existing Conditions – Emergent Zone (open water lacking littoral vegetation).



Photo 5. Existing Conditions – Erosion along lake’s east “Point”.



Photo 6. Existing Conditions – Erosion along lake’s west shoreline (south of west beach).



Photo 7. Existing Conditions – Erosion at north stormwater outfall.



Photo 8. Existing Conditions – Erosion at east stormwater outfall.



Photo 9. Existing Conditions – Minor erosion along lake's north shoreline



Photo 10. Existing Conditions – Minor erosion along lake’s east shoreline.



Photo 11. Existing Conditions – Riprap/boulders stabilizing west shoreline.



Attachment 2

MCWD Erosion Intensity Scoresheet

EROSION INTENSITY SCORESHEET

SHORELINE VARIABLES	DESCRIPTIVE CATEGORIES					EI VALUE
	EROSION INTENSITY (EI) VALUE IS LOCATED IN PARENTHESIS ON LEFT SIDE OF EACH CATEGORY BOX					North, point
AVERAGE FETCH – Average distance (miles) across open water to the opposite shore.	(0) <1/10	(2) 1/10-1/3	(4) 1/3-1	(7) 1-3	(10) >3	4,4
DEPTH AT 20 FEET – Depth of water (feet) 20 feet from the shoreline.	(1) <1	(2) 1-3	(3) 3-6	(4) 6-12	(5) >12	3,3
DEPTH AT 100 FEET – Depth of water (feet) 100 feet from the shoreline.	(1) <1	(2) 1-3	(3) 3-6	(4) 6-12	(5) >12	5,5
BANK HEIGHT – Measure from toe of bank to top of bank-lip (feet).	(1) <1	(2) 1-3	(3) 3-6	(4) 6-10	(5) >10	2,4
INFLUENCE OF ADJACENT STRUCTURES – Likelihood that adjacent structures are causing flank erosion at the site.	(0) no hard armoring on either adjacent property	(1) hard armoring on one adjacent property	(2) hard armoring on both adjacent properties	(3) hard armoring on one adjacent property with measurable recession	(4) hard armoring on both adjacent properties with measurable recession adjacent to both structures	0,0
AQUATIC VEGETATION – Type and abundance of vegetation occurring in the water off the shoreline.	(0) rocky substrates unable to support vegetation.	(1) dense or abundant emergent, floating or submergent vegetation	(4) scattered or patchy emergent, floating or submergent vegetation	(7) lack of emergent, floating or submergent vegetation		7,7
BANK VEGETATION – Type and abundance of vegetation occurring on bank face and immediately on top of bank lip.	(0) bank composed of rocky outcropping unable to support vegetation.	(1) dense vegetation, upland trees, shrubs and grasses, including lawns	(4) clumps of vegetation alternating with areas lacking vegetation	(7) minimal vegetation(due to shading or erosion)		4,4
BANK STABILITY – Degree to which bank and adjacent area (within 10 feet of bank lip) is stabilized by natural ground, shrub, and canopy vegetation. Human disturbance is typified by tree removal, brushing, mowing, and lawn establishment.	(0) established lawn with few canopy trees and/or shrubs	(1) established lawn with moderate to dense canopy trees and/or shrubs	(4) moderate to dense natural ground vegetation and canopy trees with shrub layer substantially reduced; or few canopy trees with moderate to dense natural shrub layer	(7) moderate to dense canopy trees with moderate to dense natural shrub layer; or other natural features prevents establishment of ground vegetation		7,7
SHORELINE GEOMETRY – General shape of the shoreline at the point of interest plus 200 yards on either side.	(1) cove or sheltered area		(4) irregular shoreline or straight shoreline	(8) headland, point, or island		4,8
SHORE ORIENTATION – Geographic direction the shoreline faces.	(0) <1/3 mile fetch	(1) north to east to south-southeast (349°-360°, 1°-168°)	(4) south to west-southwest (169°-258°)	(8) west to north-northwest (259°-349°)		1,8
BOAT WAKES – Proximity to and intensity of boat traffic.	(1) broad open waterbody with limited traffic; constricted shallow water body; or no-wake zone	(4) limited traffic within 200 yards; moderate traffic 200 yards to ¼ mile offshore	(8) moderate traffic within 200 yards; or intensive traffic 200 yards to ¼ mile offshore	(12) intensive traffic within 200 yards		1,1
TOTAL EROSION INTENSITY SCORE =						38,51

EROSION INTENSITY CLASSIFICATION: LOW = 5-30, MEDIUM = 31-48, HIGH = 49-78

EROSION INTENSITY SCORESHEET GUIDANCE

1. **AVERAGE FETCH*** – Fetch is the distance (miles) across open water to the opposite shoreline. Fetch is measured at a 45° angle from the shoreline on either side. The longest possible fetch is also measured. The average of these 3 values represents the average fetch.

A = Fetch at 45°
B = Fetch at 45°
C = Longest possible fetch

$$\text{Ave. Fetch} = (A + B + C) / 3$$

Note: Fetch measurements should not be taken through a channel or other narrow area where waves would not maintain their energy.

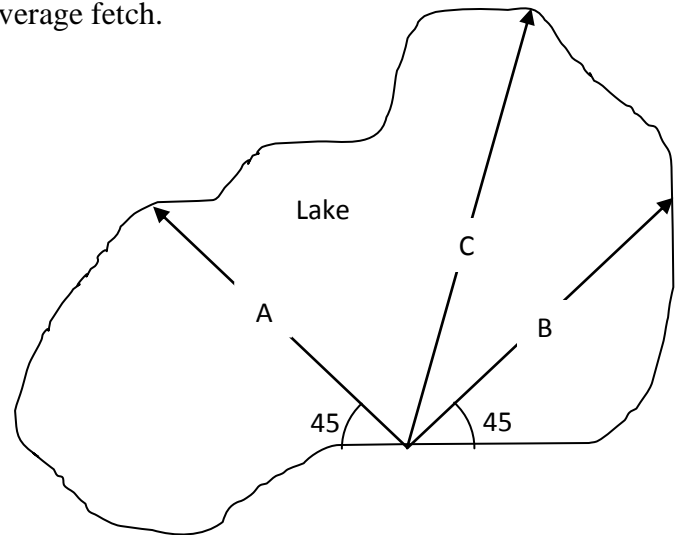

2. **DEPTHS AT 20 AND 100 FEET*** - Depths (feet) can be estimated by MCWD staff using bathymetric maps, or more precise measurements can be provided by the applicant.
3. **BANK HEIGHT** – Bank height is the vertical measure (feet) from the bank-toe to the top of the bank-lip. (Note: bank-toe may be below the water level.)

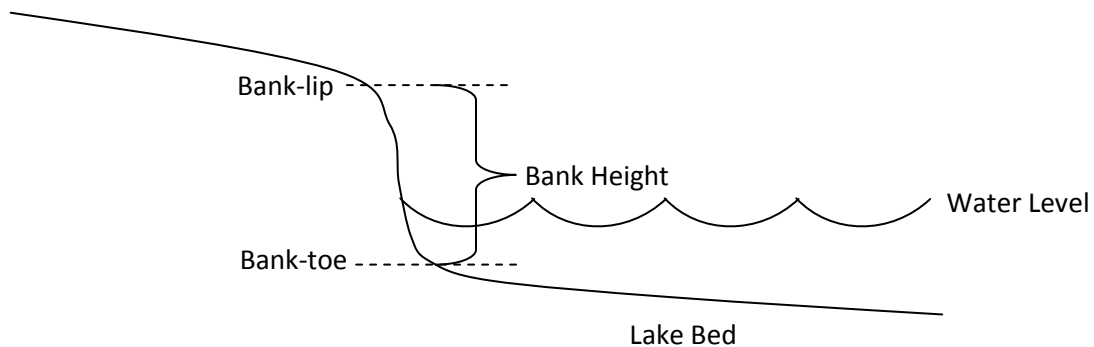

4. **AQUATIC VEGETATION** – Estimate of the percent of the lake bottom that is visually obstructed by plants during the growing season (June 1 - September 15):
 - > 50% - Dense or abundant
 - 5-50% - Scattered or patchy
 - < 5% - Lack of vegetation
5. **BANK VEGETATION** – Estimate of the percent of ground cover on the bank:
 - > 75% - Dense vegetation
 - 25-75% - Clumps of vegetation
 - < 25% - Minimal vegetation

6. **BANK STABILITY** – Represents the degree of human disturbance. A shoreline that has had little or no disturbance (with natural tree and shrub layers) but still exhibits erosion indicates that the existing vegetation may not be sufficient to stabilize the shoreline and a more structural solution may be needed. Alternatively, a shoreline that has an established lawn up to the bank may experience erosion simply due to the lack of deep-rooted vegetation, so a biological or bioengineering solution may be suitable.

7. **SHORE ORIENTATION*** –

Determining wind exposure from the direction the shoreline faces

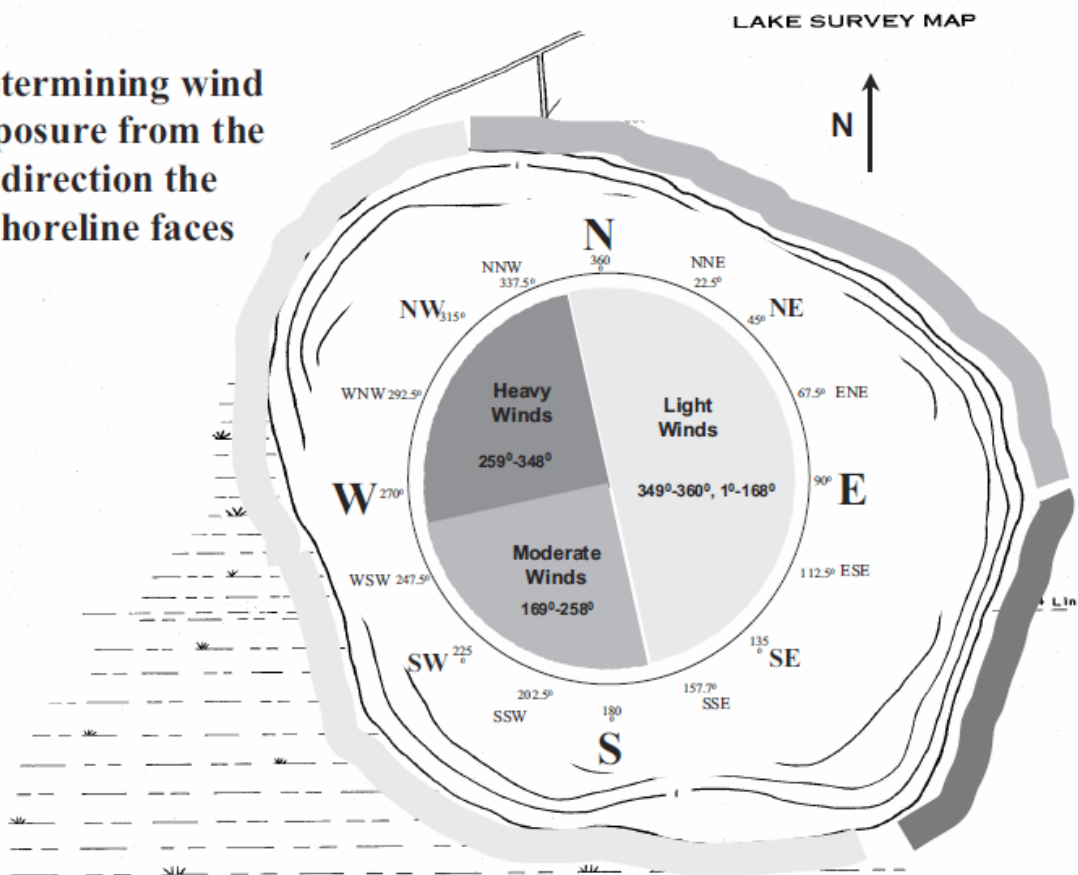

8. **BOAT WAKES** – “Intensive traffic” is defined as a major thoroughfare or an area with regular recreational traffic such as a ski lane. “Limited traffic” means a channel, bay, or lake that is generally only used by the people who live in the surrounding area.

*Values will be provided by the MCWD at the request of the applicant.

Attachment 3 Lake Nokomis Water Levels

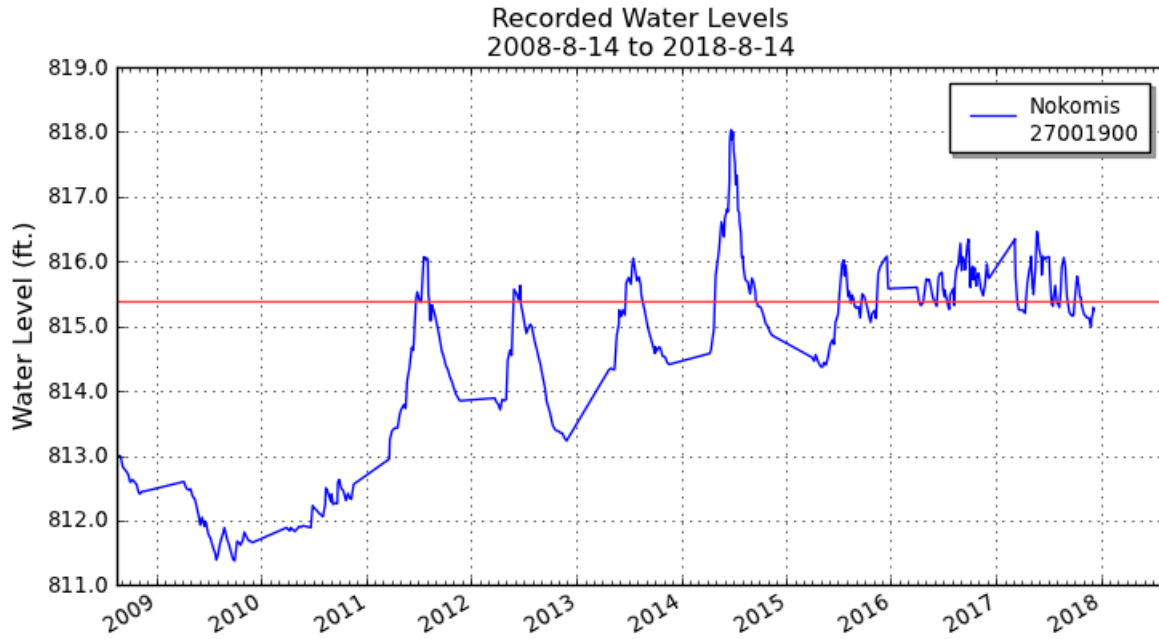

Source: MnDNR Lakefinder (<https://www.dnr.state.mn.us/lakefind/showlevel.html?downum=27001900>)

Attachment 4 Volume of Excavation & Fill Calculations

Elevation	Site 7 (North Stormwater Outfall)			Site 16 (East Stormwater Outfall)			Curb Cut Swale			Project Total cf
	Cut cf	Fill cf	Net cf	Cut cf	Fill cf	Net cf	Cut cf	Fill cf	Net cf	
815										0
816		60.4	60.4	-59.6		-59.6				0.8
817		115.7	115.7	-179.0		-179.0				-63.3
818		59.1	59.1	-119.4		-119.4				-60.3
819		3.8	3.8							3.8
Above Floodplain (834-835)								119.0	119.0	119.0

Fill (+) or Cut (-) Total for Project: 0.0 cf (no net soil import/export from project area)

Fill (+) or Cut (-) Total w/in Floodplain: -119.0 cf or -4.4 cy

Ordinary High Water Level: 815.4

100-Yr Floodplain Elevation: 820.0

Assumptions:

- Riprap not counted as fill because riprap will be placed on locations where soil has eroded from its original condition.

REQUEST FOR EXCEPTION FROM A RULE PROVISION

MINNEHAHA CREEK WATERSHED DISTRICT (MCWD)
15320 MINNETONKA BLVD.
MINNETONKA, MN 55345

Phone: 952-471-0590
Fax: 952-471-0682

A request for an exception must be accompanied by a MCWD Water Resources Application

Project Details:

Project address: Lake Nokomis City: Minneapolis State: MN Zip: 55417
County: Hennepin Property ID number (PID): Multiple

The Board of Managers may grant an exception from a provision of the rules on a determination that the proposed application will achieve a greater degree of water resource protection than would strict compliance with the provision. An exception must be approved by a two-thirds majority of managers voting.

Exception Requested From MCWD Rule(s):

- | | |
|---|---|
| <input type="checkbox"/> Erosion Control | <input type="checkbox"/> Waterbody Crossings & Structures |
| <input type="checkbox"/> Floodplain Alteration | <input type="checkbox"/> Stormwater Management |
| <input checked="" type="checkbox"/> Wetland Protection | <input type="checkbox"/> Appropriations |
| <input type="checkbox"/> Shoreline & Streambank Stabilization | <input type="checkbox"/> Illicit Discharge |

Provision(s) and Requirement(s) of the Rule(s):

Minimum wetland buffer width and area.

Requested Exception:

Provide 2.5 acres of upland buffer, instead of the required 6.9 acres with a width ranging from 0-60 feet instead of the required 67 feet. The proposed total vegetative restoration area is 4.5 acres.

Describe how the proposed design will achieve a greater degree of water resource protection than strict compliance with the provision, referring to the impacts on water quality, water quantity, and ecological integrity. Quantify water resource protection as much as possible (pounds of pollutant removal, acres of habitat creation, etc).

The project design includes a spectrum of habitat including emergent, riparian, and upland areas which will be restored with native vegetation. The smaller native buffer combined with the wetland and emergent areas will provide a higher quality of habitat than the required buffer made up of unmowed turf grass and invasive species, which results in a greater habitat benefit than strict compliance with the rule. The combination of treatments supports a greater diversity of species and species throughout their lifecycle and seasons. The stormwater filtration benefits of the buffer are provided through the establishment of the 4.5 acres of native vegetation, which provides greater filtration and the installation of a hydrodynamic separator to remove sediment from storm sewer discharge. The stormwater flow from the outfall has a higher sediment concentration than the water that would flow through the buffer, which is primarily runoff from grassy areas in the park, instead of more sediment laden streets.

MINNEAPOLIS PARK & RECREATION BOARD LAKE NOKOMIS SHORELINE ENHANCEMENT

CONSTRUCTION PLANS FOR SHORELINE STABILIZATION, STORMWATER OUTFALL REPAIRS, AND LANDSCAPING.

DRAFT – NOT FOR CONSTRUCTION

PLAN SYMBOLS

STATE LINE	----
COUNTY LINE	----
TOWNSHIP OR RANGE LINE	----
SECTION LINE	----
QUARTER LINE	----
SIXTEENTH LINE	----
RIGHT-OF-WAY LINE	----
PRESENT RIGHT-OF-WAY LINE	----
CONTROL OF ACCESS LINE	----
PROPERTY LINE (Except Land Lines)	----
VACATED PLATTED PROPERTY	----
CORPORATE OR CITY LIMITS	----
TRUNK HIGHWAY CENTER LINE	----
CONC. RETAINING WALL	----
RAILROAD	----
RAILROAD RIGHT-OF-WAY LINE	----
RIVER OR CREEK	----
DRY RUN	----
DRAINAGE DITCH	----
DRAIN TILE	----
CULVERT	----
DROP INLET	----
GUARD RAIL	----
BARBED WIRE FENCE	----
WOVEN WIRE FENCE	----
CHAIN LINK FENCE	----
RAILROAD SNOW FENCE	----
STONE WALL OR FENCE	----
HEDGE	----
RAILROAD CROSSING SIGN	----
RAILROAD CROSSING BELL	----
ELECTRIC WARNING SIGN	----
CROSSING GATE	----
MEANDER CORNER	----
MAIL BOX	----
SPRINGS	----
MARSH	----
TIMBER	----
ORCHARD	----
BRUSH	----
NURSERY	----
CATCH BASIN	C.B. □
FIRE HYDRANT	----
CATTLE GUARD	----
OVERPASS (Highway Over)	----
UNDERPASS (Highway Under)	----
BRIDGE	----
BUILDING (One Story Frame)	----
F-FRAME C-CONCRETE	
S-STONE T-TILE	
B-BRICK ST-STUCCO	
IRON PIPE OR ROD	----
MONUMENT (STONE, CONCRETE, OR METAL)	----
WOODEN HUB	----
GRAVEL PIT	○
SAND PIT	○
BORROW PIT	○
ROCK QUARRY	○

UTILITY SYMBOLS

POWER POLE LINE	----
TELEPHONE OR TELEGRAPH POLE LINE	----
JOINT TELEPHONE AND POWER ON POWER POLES	----
JOINT TELEPHONE AND POWER ON TELEPHONE POLES	----
ANCHOR	↑
STEEL TOWER	△
STREET LIGHT	○
PEDESTAL (TELEPHONE CABLE TERMINAL)	□
GAS MAIN	----
WATER MAIN	----
CONDUIT	----
TELEPHONE CABLE IN CONDUIT	----
ELECTRIC CABLE IN CONDUIT	----
TELEPHONE MANHOLE	□
ELECTRIC MANHOLE	□
BURIED TELEPHONE CABLE	T-BUR
BURIED ELECTRIC CABLE	P-BUR
AERIAL TELEPHONE CABLE	----
SEWER, (SANITARY)	----
SEWER, (STORM)	----
SEWER MANHOLE	□
HANDHOLE	□

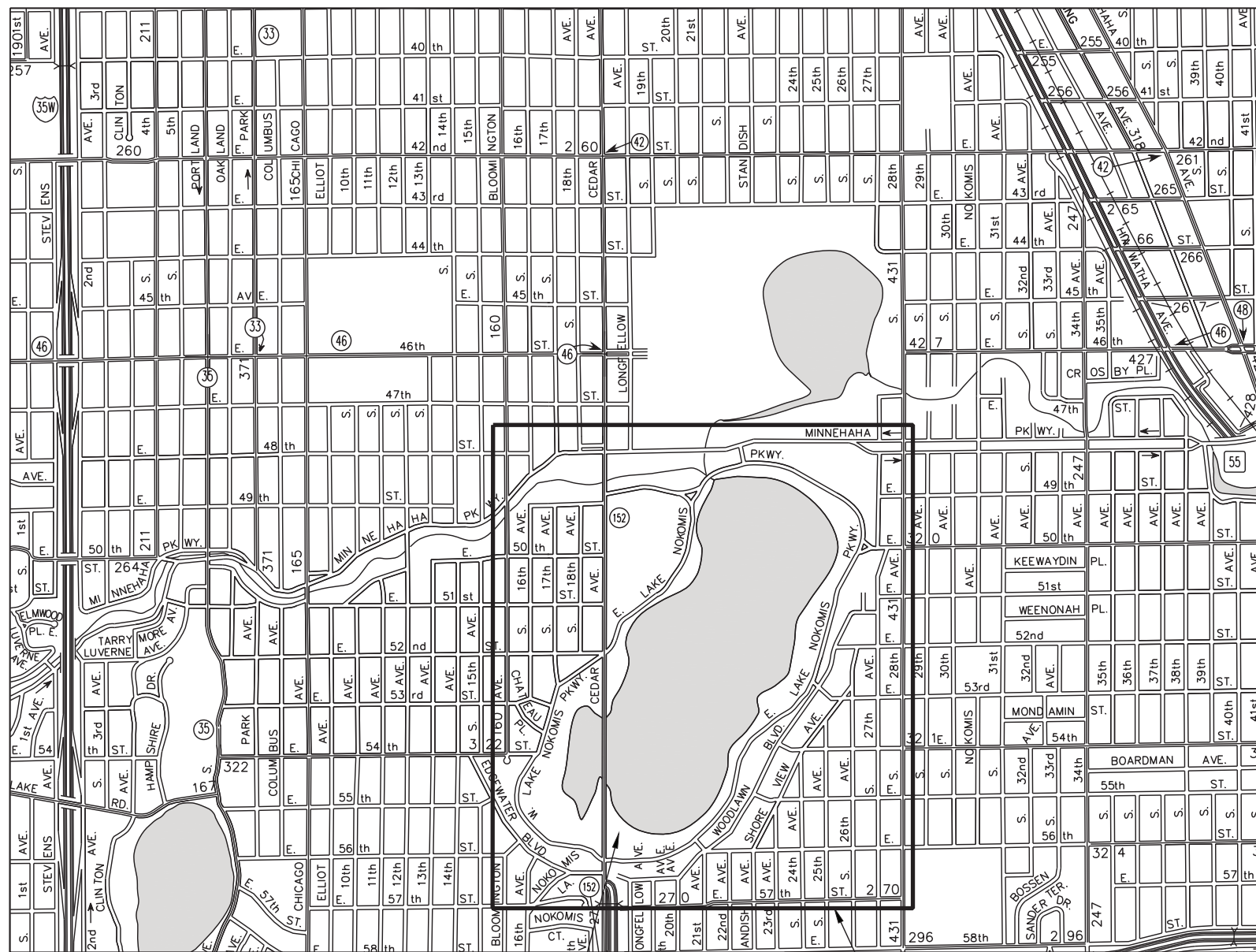
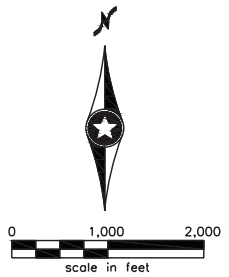

LAKE NOKOMIS REGIONAL PARK

PROJECT LOCATION

GOVERNING SPECIFICATIONS
THE 2018 EDITION OF THE MINNESOTA DEPARTMENT OF TRANSPORTATION "STANDARD SPECIFICATIONS FOR CONSTRUCTION" SHALL GOVERN.

I HEREBY CERTIFY THAT THIS PLAN, SPECIFICATION, OR REPORT WAS PREPARED BY ME OR UNDER MY DIRECT SUPERVISION AND THAT I AM A DULY LICENSED PROFESSIONAL LANDSCAPE ARCHITECT UNDER THE LAWS OF THE STATE OF MINNESOTA.

PRINT NAME: SEAN JERGENS

DATE: _____

LICENSE #: _____

I HEREBY CERTIFY THAT THIS PLAN, SPECIFICATION, OR REPORT WAS PREPARED BY ME OR UNDER MY DIRECT SUPERVISION AND THAT I AM A DULY LICENSED PROFESSIONAL ENGINEER UNDER THE LAWS OF THE STATE OF MINNESOTA.

PRINT NAME: LEAH GIFFORD

DATE: _____

LICENSE #: _____

SHEET INDEX

1	COVER SHEET/INDEX
2	GENERAL & EROSION CONTROL NOTES
3	OVERALL LAYOUT
4 - 18	LANDSCAPE PLANS
19 - 23	LANDSCAPE DETAILS
24	DRAINAGE REMOVALS
25	DRAINAGE PLAN & PROFILES
26 - 32	DRAINAGE DETAILS
33 - 35	SWPPP

THE SUBSURFACE UTILITY INFORMATION IN THIS PLAN IS UTILITY QUALITY LEVEL D. THIS QUALITY LEVEL WAS DETERMINED ACCORDING TO GUIDELINES OF CI/ASCE 38-02, ENTITLED "STANDARD GUIDELINES FOR THE COLLECTION AND DEPICTION OF EXISTING SUBSURFACE UTILITY DATA".

SEAN JERGENS 11/9/2018 5:20:55 PM H:\PROJECTS\10000\10547\CAD_BM\PLAN\10547_TSH.DWG: 001

NO	DATE	BY	CKD	APPR

I hereby certify that this plan, specification, or report was prepared by me or under my direct supervision and that I am a duly Licensed Professional Landscape Architect under the laws of the State of Minnesota.
Print Name: SEAN JERGENS
Date OCTOBER 12, 2018 License # _____

CITY PROJECT NO. ##
COMM. NO. 10547

DRAWN BY R. BURAND
DESIGNED BY S. JERGENS
CHECKED BY S. JERGENS

MINNEAPOLIS PARK & RECREATION BOARD
COVER SHEET/INDEX
LAKE NOKOMIS SHORELINE ENHANCEMENT

SHEET 1 OF 35



SEAN JERGENS 10/13/2018 8:01:30 AM
 H:\PROJECTS\10000\10547\CAD_BIM\PLAN\10547_LAN.DWG: 002

NO	DATE	BY	CKD	APPR

I hereby certify that this plan, specification, or report was prepared by me or under my direct supervision and that I am a duly Licensed Professional Landscape Architect under the laws of the State of Minnesota.
 Print Name: SEAN JERGENS
 Date OCTOBER 12, 2018 License # #####

DRAWN BY
 R. BURAND
 DESIGNED BY
 S. JERGENS
 CHECKED BY
 S. JERGENS
 COMM. NO. 10547



MINNEAPOLIS PARK & RECREATION BOARD
 OVERALL LAYOUT
 LAKE NOKOMIS SHORELINE ENHANCEMENT

SHEET
 3
 OF
 35

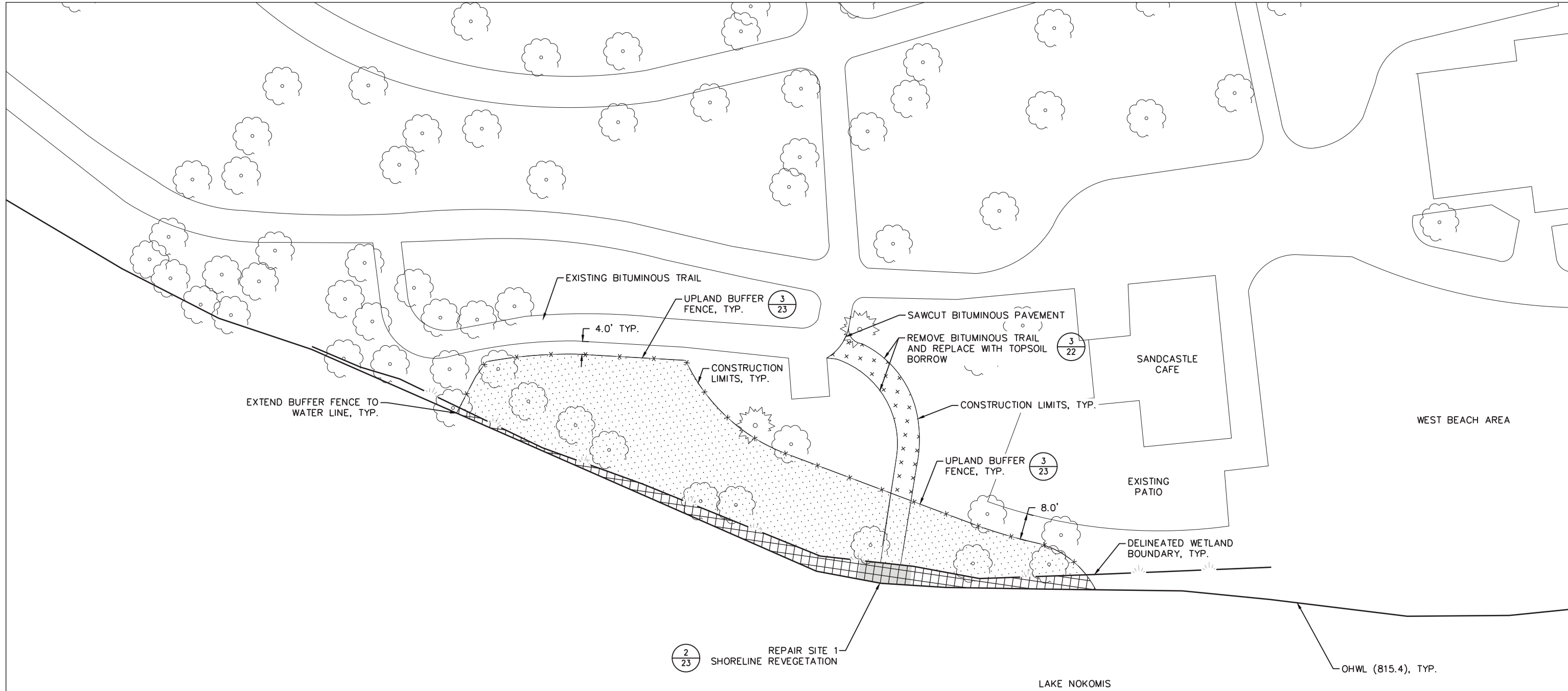

LEGEND	
	UPLAND BUFFER ZONE (SEED MIX 1) BWSR "LOW GROWING SOLAR ARRAY SOUTH & WEST" - MODIFIED
	SHORELINE ZONE (SEED MIX 2) MN STATE SEED MIX 34-261
	DELINEATED WETLAND BOUNDARY, TYP.
	100-YR FLOODPLAIN BOUNDARY (ELEV. 820.0)
	WAVE BREAK / FISH EXCLUSION FENCE (SEE DTL. 4/23)
	UPLAND BUFFER FENCE (SEE DTL. 3/23)
	EMERGENT ZONE SEE PLANT SCHEDULE
	LOW MAINT. TURF (SEED MIX 3) MN STATE SEED MIX 25-131
	EROSION CONTROL BLANKET CAT. 2 WITH SHORELINE ZONE SEED MIX
	TURF REINFORCEMENT MAT (TRM) CAT. 2
	EXISTING TREE

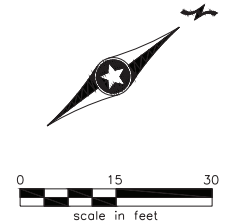

- NOTES:**
1. ALL GENERAL NOTES FROM SHEET 2 SHALL APPLY.
 2. REPORT ALL LAYOUT DISCREPANCIES IMMEDIATELY TO THE LANDSCAPE ARCHITECT FOR DIRECTION PRIOR TO PROCEEDING.
 3. WRITTEN DIMENSIONS SHALL PREVAIL OVER DRAWING.
 4. PROTECT ALL EXISTING VEGETATION NOT SCHEDULED FOR REMOVAL. ALL DISTURBED AREAS OUTSIDE OF THE CONSTRUCTION LIMITS SHALL BE REPAIRED TO EXISTING CONDITION BY THE CONTRACTOR.
 5. ALL INVASIVE WOODY AND ALL INVASIVE HERBACEOUS VEGETATION WITHIN THE CONSTRUCTION LIMITS SHALL BE REMOVED BY THE CONTRACTOR. USE OF HERBICIDE SHALL COMPLY WITH MPRB REQUIREMENTS. SEE SPECIAL PROVISIONS FOR MORE INFORMATION.
 6. VEGETATION REMOVAL AND SEEDBED PREPARATION PER MNDOT 2545. SEEDING PER MNDOT 2575. SEE SPECIAL PROVISIONS FOR MORE INFORMATION.
 7. PROJECT SITE MUST BE KEPT CLEAN AND FREE OF DEBRIS.
 8. CONTRACTOR SHALL STAKE ALL HERBICIDE, SEEDING, RIP RAP PLACEMENT, AND PLANTING LOCATIONS FOR APPROVAL BY ENGINEER PRIOR TO INSTALLATION.
 9. SEE PLANT SCHEDULE ON SHEET 21.
 10. REFER TO PROJECT SPECIFICATIONS FOR ADDITIONAL REQUIREMENTS.

I hereby certify that this plan, specification, or report was prepared by me or under my direct supervision and that I am a duly Licensed Professional Landscape Architect under the laws of the State of Minnesota.
 Print Name: SEAN JERGENS
 Date: OCTOBER 12, 2018 License # _____

DRAWN BY
R. BURAND
 DESIGNED BY
S. JERGENS
 CHECKED BY
S. JERGENS
 COMM. NO. 10547



SEAN_JERGENS.dwg | 10/13/2018 8:01:30 AM
 H:\PROJECTS\10000\10547\CAD_BIM\PLAN\10547_LAN.DWG: 003

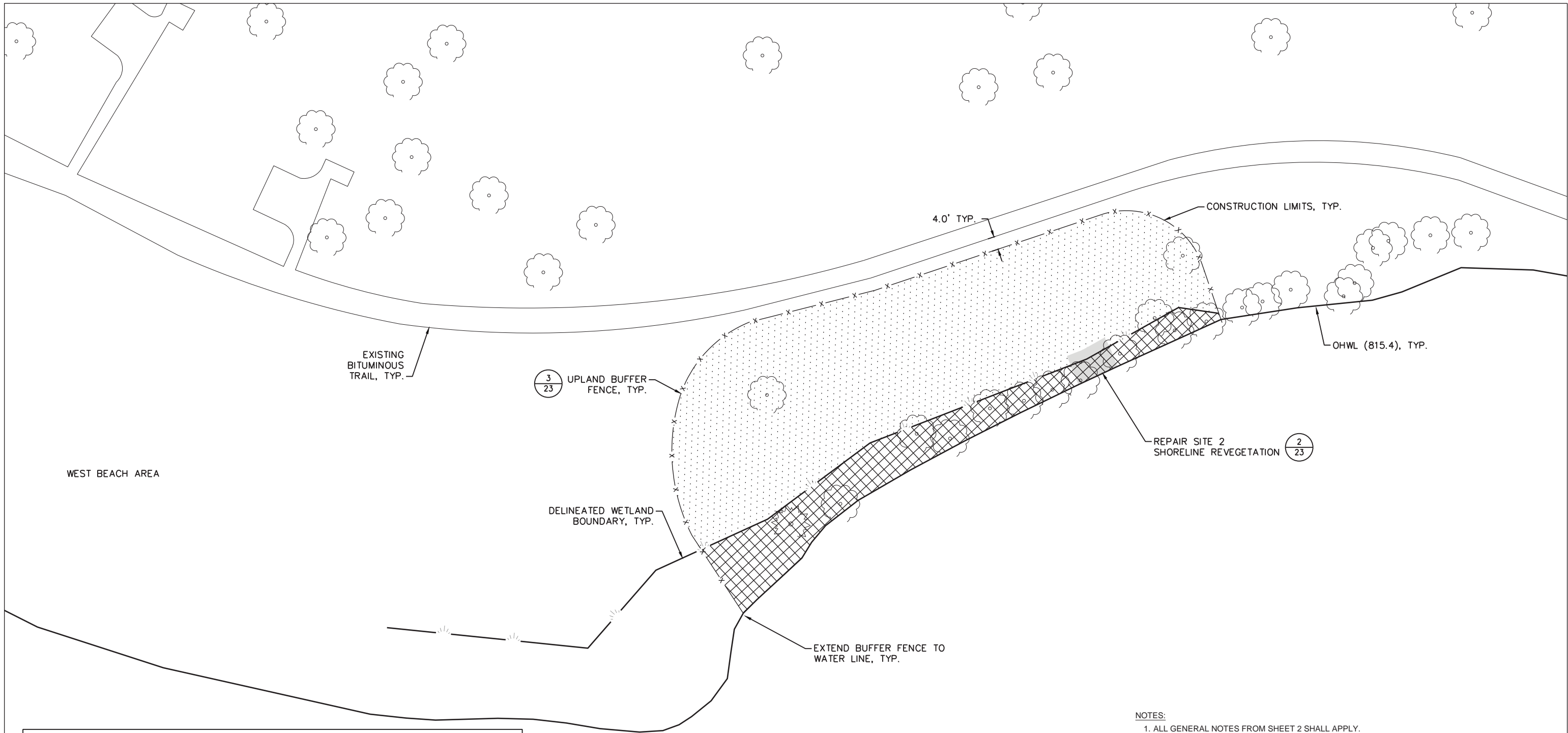

LEGEND	
	UPLAND BUFFER ZONE (SEED MIX 1) BWSR "LOW GROWING SOLAR ARRAY SOUTH & WEST" - MODIFIED
	SHORELINE ZONE (SEED MIX 2) MN STATE SEED MIX 34-261
	DELINEATED WETLAND BOUNDARY, TYP.
	100-YR FLOODPLAIN BOUNDARY (ELEV. 820.0)
	WAVE BREAK / FISH EXCLUSION FENCE (SEE DTL. 4/23)
	UPLAND BUFFER FENCE (SEE DTL. 3/23)
	EMERGENT ZONE SEE PLANT SCHEDULE
	LOW MAINT. TURF (SEED MIX 3) MN STATE SEED MIX 25-131
	EROSION CONTROL BLANKET CAT. 2 WITH SHORELINE ZONE SEED MIX
	TURF REINFORCEMENT MAT (TRM) CAT. 2
	EXISTING TREE

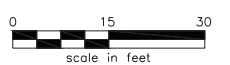

- NOTES:**
1. ALL GENERAL NOTES FROM SHEET 2 SHALL APPLY.
 2. REPORT ALL LAYOUT DISCREPANCIES IMMEDIATELY TO THE LANDSCAPE ARCHITECT FOR DIRECTION PRIOR TO PROCEEDING.
 3. WRITTEN DIMENSIONS SHALL PREVAIL OVER DRAWING.
 4. PROTECT ALL EXISTING VEGETATION NOT SCHEDULED FOR REMOVAL. ALL DISTURBED AREAS OUTSIDE OF THE CONSTRUCTION LIMITS SHALL BE REPAIRED TO EXISTING CONDITION BY THE CONTRACTOR.
 5. ALL INVASIVE WOODY AND ALL INVASIVE HERBACEOUS VEGETATION WITHIN THE CONSTRUCTION LIMITS SHALL BE REMOVED BY THE CONTRACTOR. USE OF HERBICIDE SHALL COMPLY WITH MPRB REQUIREMENTS. SEE SPECIAL PROVISIONS FOR MORE INFORMATION.
 6. VEGETATION REMOVAL AND SEEDBED PREPARATION PER MNDOT 2545. SEEDING PER MNDOT 2575. SEE SPECIAL PROVISIONS FOR MORE INFORMATION.
 7. PROJECT SITE MUST BE KEPT CLEAN AND FREE OF DEBRIS.
 8. CONTRACTOR SHALL STAKE ALL HERBICIDE, SEEDING, RIP RAP PLACEMENT, AND PLANTING LOCATIONS FOR APPROVAL BY ENGINEER PRIOR TO INSTALLATION.
 9. SEE PLANT SCHEDULE ON SHEET 21.
 10. REFER TO PROJECT SPECIFICATIONS FOR ADDITIONAL REQUIREMENTS.

I hereby certify that this plan, specification, or report was prepared by me or under my direct supervision and that I am a duly Licensed Professional Landscape Architect under the laws of the State of Minnesota.
 Print Name: SEAN JERGENS
 Date: OCTOBER 12, 2018 License # #####

DRAWN BY
R. BURAND
 DESIGNED BY
S. JERGENS
 CHECKED BY
S. JERGENS
 COMM. NO. 10547



MINNEAPOLIS PARK & RECREATION BOARD
 LANDSCAPE PLANS
 LAKE NOKOMIS SHORELINE ENHANCEMENT

SHEET
5
OF
35

SEAN_JERGENS.dwg | 10/13/2018 8:05:46 AM | H:\Projects\10000\10547\CAD_BIM\PLAN\10547_LAN.DWG: 004
 H:\Projects\10000\10547\CAD_BIM\PLAN\10547_LAN.dwg: 004

NO	DATE	BY	CHKD	APPR

H:\PROJECTS\10000\10547\CAD_BIM\PLAN\10547_LAN.DWG: 004

NOTES:

1. ALL GENERAL NOTES FROM SHEET 2 SHALL APPLY.
2. REPORT ALL LAYOUT DISCREPANCIES IMMEDIATELY TO THE LANDSCAPE ARCHITECT FOR DIRECTION PRIOR TO PROCEEDING.
3. WRITTEN DIMENSIONS SHALL PREVAIL OVER DRAWING.
4. PROTECT ALL EXISTING VEGETATION NOT SCHEDULED FOR REMOVAL. ALL DISTURBED AREAS OUTSIDE OF THE CONSTRUCTION LIMITS SHALL BE REPAIRED TO EXISTING CONDITION BY THE CONTRACTOR.
5. ALL INVASIVE WOODY AND ALL INVASIVE HERBACEOUS VEGETATION WITHIN THE CONSTRUCTION LIMITS SHALL BE REMOVED BY THE CONTRACTOR. USE OF HERBICIDE SHALL COMPLY WITH MPRB REQUIREMENTS. SEE SPECIAL PROVISIONS FOR MORE INFORMATION.
6. VEGETATION REMOVAL AND SEEDBED PREPARATION PER MNDOT 2545. SEEDING PER MNDOT 2575. SEE SPECIAL PROVISIONS FOR MORE INFORMATION.
7. PROJECT SITE MUST BE KEPT CLEAN AND FREE OF DEBRIS.
8. CONTRACTOR SHALL STAKE ALL HERBICIDE, SEEDING, RIP RAP PLACEMENT, AND PLANTING LOCATIONS FOR APPROVAL BY ENGINEER PRIOR TO INSTALLATION.
9. SEE PLANT SCHEDULE ON SHEET 21.
10. REFER TO PROJECT SPECIFICATIONS FOR ADDITIONAL REQUIREMENTS.

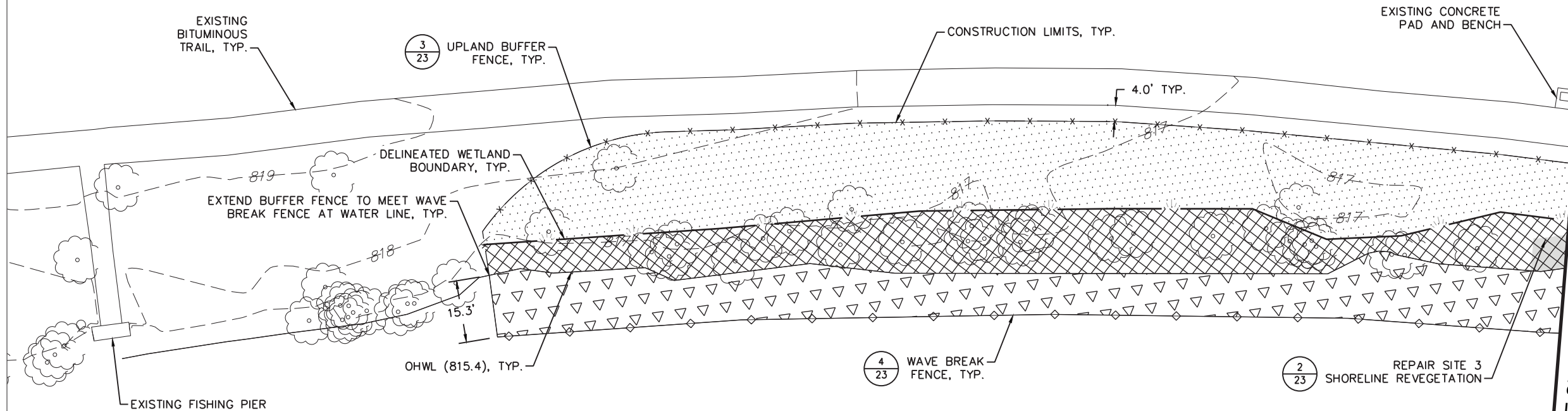

MATCHLINE - SEE SHEET 7

LEGEND	
	UPLAND BUFFER ZONE (SEED MIX 1) BWSR "LOW GROWING SOLAR ARRAY SOUTH & WEST" - MODIFIED
	SHORELINE ZONE (SEED MIX 2) MN STATE SEED MIX 34-261
	DELINEATED WETLAND BOUNDARY, TYP.
	100-YR FLOODPLAIN BOUNDARY (ELEV. 820.0)
	WAVE BREAK / FISH EXCLUSION FENCE (SEE DTL. 4/23)
	UPLAND BUFFER FENCE (SEE DTL. 3/23)
	EMERGENT ZONE SEE PLANT SCHEDULE
	LOW MAINT. TURF (SEED MIX 3) MN STATE SEED MIX 25-131
	EROSION CONTROL BLANKET CAT. 2 WITH SHORELINE ZONE SEED MIX
	TURF REINFORCEMENT MAT (TRM) CAT. 2
	EXISTING TREE

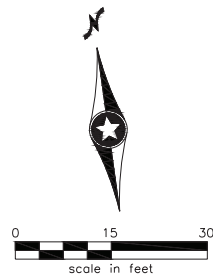

SEAN_JERGENS.dwg | 10/13/2018 8:05:46 AM | H:\PROJECTS\10000\10547\CAD_BIM\PLAN\10547_LAN.DWG: 005

NO	DATE	BY	CKD	APPR

I hereby certify that this plan, specification, or report was prepared by me or under my direct supervision and that I am a duly Licensed Professional Landscape Architect under the laws of the State of Minnesota.
 Print Name: SEAN JERGENS
 Date: OCTOBER 12, 2018 License # _____

DRAWN BY: R. BURAND
 DESIGNED BY: S. JERGENS
 CHECKED BY: S. JERGENS
 COMM. NO. 10547



MINNEAPOLIS PARK & RECREATION BOARD
 LANDSCAPE PLANS
 LAKE NOKOMIS SHORELINE ENHANCEMENT

SHEET 6 OF 35

NOTES:

1. ALL GENERAL NOTES FROM SHEET 2 SHALL APPLY.
2. REPORT ALL LAYOUT DISCREPANCIES IMMEDIATELY TO THE LANDSCAPE ARCHITECT FOR DIRECTION PRIOR TO PROCEEDING.
3. WRITTEN DIMENSIONS SHALL PREVAIL OVER DRAWING.
4. PROTECT ALL EXISTING VEGETATION NOT SCHEDULED FOR REMOVAL. ALL DISTURBED AREAS OUTSIDE OF THE CONSTRUCTION LIMITS SHALL BE REPAIRED TO EXISTING CONDITION BY THE CONTRACTOR.
5. ALL INVASIVE WOODY AND ALL INVASIVE HERBACEOUS VEGETATION WITHIN THE CONSTRUCTION LIMITS SHALL BE REMOVED BY THE CONTRACTOR. USE OF HERBICIDE SHALL COMPLY WITH MPRB REQUIREMENTS. SEE SPECIAL PROVISIONS FOR MORE INFORMATION.
6. VEGETATION REMOVAL AND SEEDBED PREPARATION PER MNDOT 2545. SEEDING PER MNDOT 2575. SEE SPECIAL PROVISIONS FOR MORE INFORMATION.
7. PROJECT SITE MUST BE KEPT CLEAN AND FREE OF DEBRIS.
8. CONTRACTOR SHALL STAKE ALL HERBICIDE, SEEDING, RIP RAP PLACEMENT, AND PLANTING LOCATIONS FOR APPROVAL BY ENGINEER PRIOR TO INSTALLATION.
9. SEE PLANT SCHEDULE ON SHEET 21.
10. REFER TO PROJECT SPECIFICATIONS FOR ADDITIONAL REQUIREMENTS.

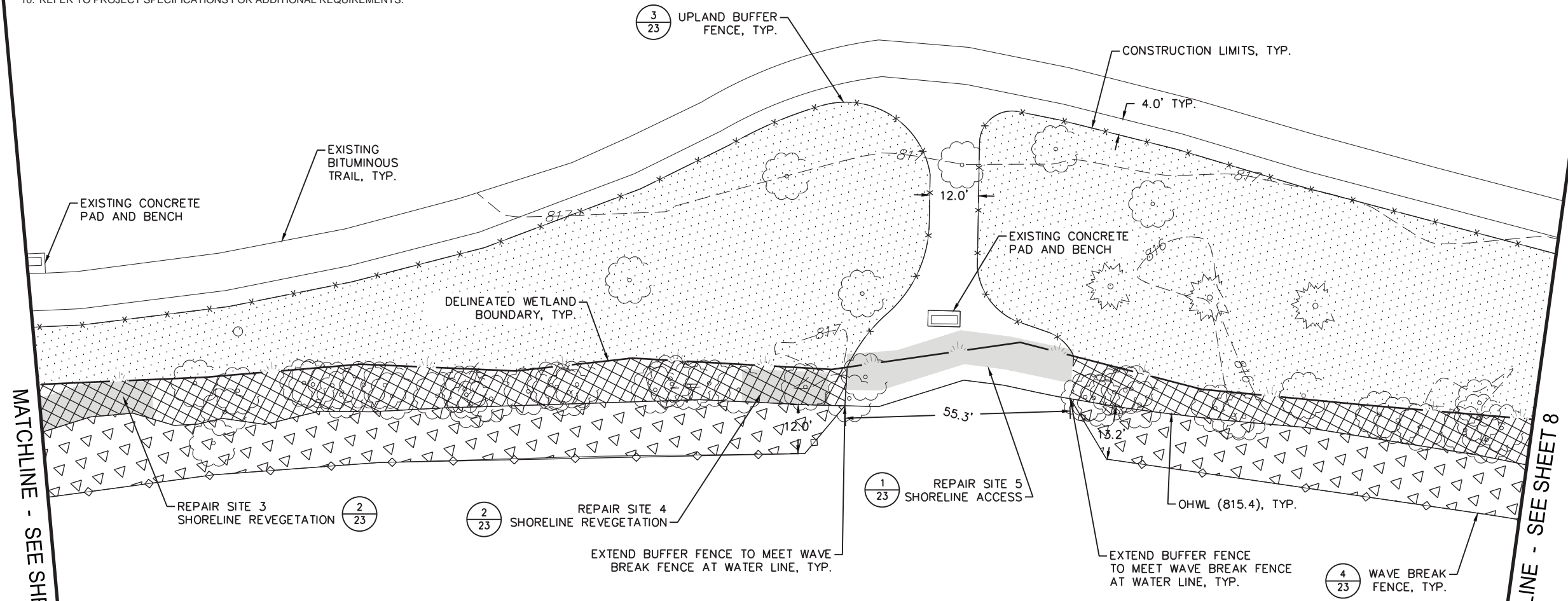

LEGEND

UPLAND BUFFER ZONE (SEED MIX 1) BWSR "LOW GROWING SOLAR ARRAY SOUTH & WEST" - MODIFIED	EMERGENT ZONE SEE PLANT SCHEDULE
SHORELINE ZONE (SEED MIX 2) MN STATE SEED MIX 34-261	LOW MAINT. TURF (SEED MIX 3) MN STATE SEED MIX 25-131
DELINEATED WETLAND BOUNDARY, TYP.	EROSION CONTROL BLANKET CAT. 2 WITH SHORELINE ZONE SEED MIX
100-YR FLOODPLAIN BOUNDARY (ELEV. 820.0)	TURF REINFORCEMENT MAT (TRM) CAT. 2
WAVE BREAK / FISH EXCLUSION FENCE (SEE DTL. 4/23)	EXISTING TREE
UPLAND BUFFER FENCE (SEE DTL. 3/23)	

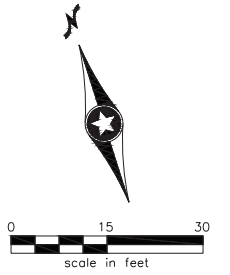

SEAN_JERGENS_10/13/2018 8:05:46 AM
 H:\PROJECTS\10000\10547\CAD_BIM\PLAN\10547_LAN.DWG: 006

NO	DATE	BY	CKD	APPR

I hereby certify that this plan, specification, or report was prepared by me or under my direct supervision and that I am a duly Licensed Professional Landscape Architect under the laws of the State of Minnesota.
 Print Name: SEAN JERGENS
 Date: OCTOBER 12, 2018 License # _____

CITY PROJECT NO. ##
 DRAWN BY: R. BURAND
 DESIGNED BY: S. JERGENS
 CHECKED BY: S. JERGENS
 COMM. NO. 10547



MINNEAPOLIS PARK & RECREATION BOARD
 LANDSCAPE PLANS
 LAKE NOKOMIS SHORELINE ENHANCEMENT

SHEET
 7
 OF
 35

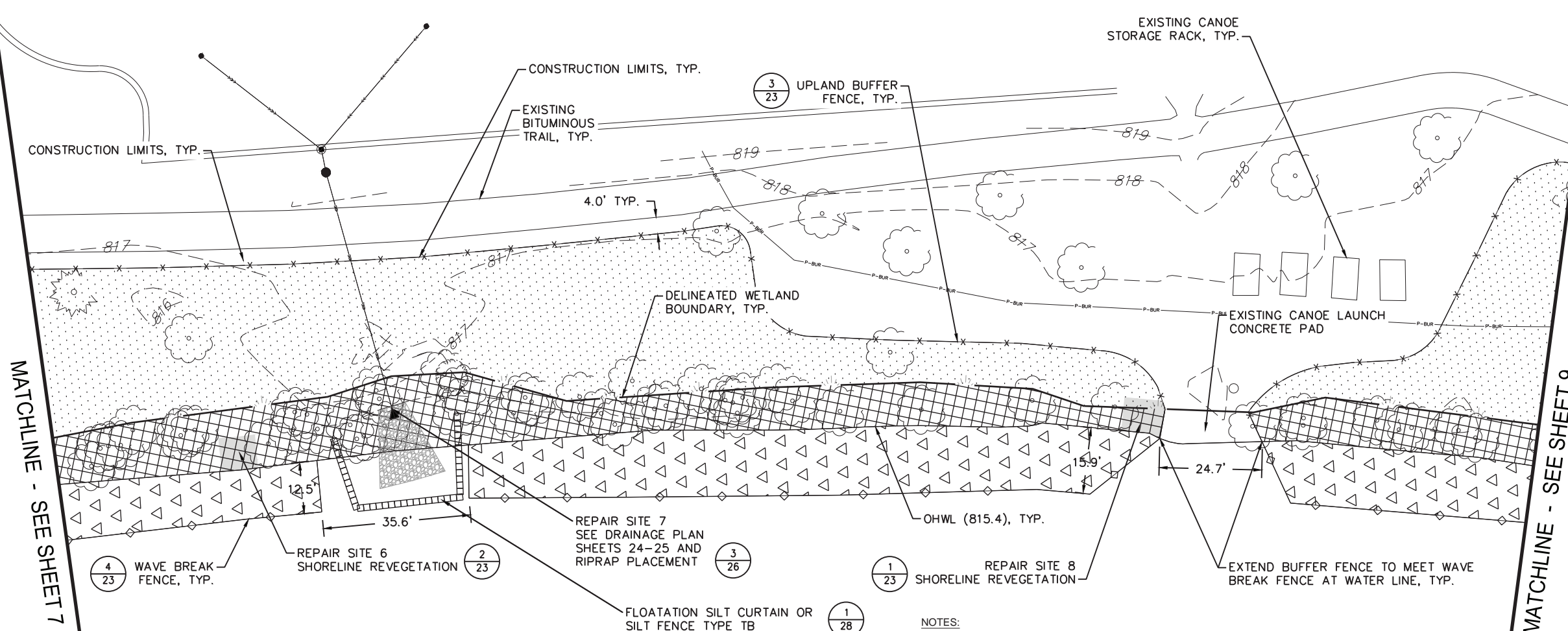

MATCHLINE - SEE SHEET 7

MATCHLINE - SEE SHEET 9

LEGEND	
	UPLAND BUFFER ZONE (SEED MIX 1) BSR "LOW GROWING SOLAR ARRAY SOUTH & WEST" - MODIFIED
	SHORELINE ZONE (SEED MIX 2) MN STATE SEED MIX 34-261
	DELINEATED WETLAND BOUNDARY, TYP.
	100-YR FLOODPLAIN BOUNDARY (ELEV. 820.0)
	WAVE BREAK / FISH EXCLUSION FENCE (SEE DTL. 4/23)
	UPLAND BUFFER FENCE (SEE DTL. 3/23)
	EMERGENT ZONE SEE PLANT SCHEDULE
	LOW MAINT. TURF (SEED MIX 3) MN STATE SEED MIX 25-131
	EROSION CONTROL BLANKET CAT. 2 WITH SHORELINE ZONE SEED MIX
	TURF REINFORCEMENT MAT (TRM) CAT. 2
	EXISTING TREE

- NOTES:**
1. ALL GENERAL NOTES FROM SHEET 2 SHALL APPLY.
 2. REPORT ALL LAYOUT DISCREPANCIES IMMEDIATELY TO THE LANDSCAPE ARCHITECT FOR DIRECTION PRIOR TO PROCEEDING.
 3. WRITTEN DIMENSIONS SHALL PREVAIL OVER DRAWING.
 4. PROTECT ALL EXISTING VEGETATION NOT SCHEDULED FOR REMOVAL. ALL DISTURBED AREAS OUTSIDE OF THE CONSTRUCTION LIMITS SHALL BE REPAIRED TO EXISTING CONDITION BY THE CONTRACTOR.
 5. ALL INVASIVE WOODY AND ALL INVASIVE HERBACEOUS VEGETATION WITHIN THE CONSTRUCTION LIMITS SHALL BE REMOVED BY THE CONTRACTOR. USE OF HERBICIDE SHALL COMPLY WITH MPRB REQUIREMENTS. SEE SPECIAL PROVISIONS FOR MORE INFORMATION.
 6. VEGETATION REMOVAL AND SEEDBED PREPARATION PER MNDOT 2545. SEEDING PER MNDOT 2575. SEE SPECIAL PROVISIONS FOR MORE INFORMATION.
 7. PROJECT SITE MUST BE KEPT CLEAN AND FREE OF DEBRIS.
 8. CONTRACTOR SHALL STAKE ALL HERBICIDE, SEEDING, RIP RAP PLACEMENT, AND PLANTING LOCATIONS FOR APPROVAL BY ENGINEER PRIOR TO INSTALLATION.
 9. SEE PLANT SCHEDULE ON SHEET 21.
 10. REFER TO PROJECT SPECIFICATIONS FOR ADDITIONAL REQUIREMENTS.

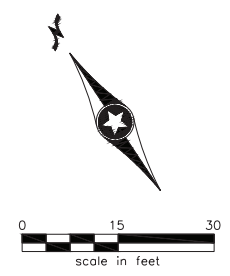

SEAN_JERGENS.dwg | 10/13/2018 8:05:46 AM | H:\PROJECTS\10000\10547\CAD_BIM\PLAN\10547_LAN.DWG: 007

NO	DATE	BY	CKD	APPR

I hereby certify that this plan, specification, or report was prepared by me or under my direct supervision and that I am a duly Licensed Professional Landscape Architect under the laws of the State of Minnesota.
 Print Name: SEAN JERGENS
 Date: OCTOBER 12, 2018 License # _____ CITY PROJECT NO. ## _____

DRAWN BY
R. BURAND
 DESIGNED BY
S. JERGENS
 CHECKED BY
S. JERGENS
 COMM. NO. 10547



MINNEAPOLIS PARK & RECREATION BOARD
 LANDSCAPE PLANS
 LAKE NOKOMIS SHORELINE ENHANCEMENT

SHEET
8
OF
35

MATCHLINE - SEE SHEET 8

MATCHLINE - SEE SHEET 10

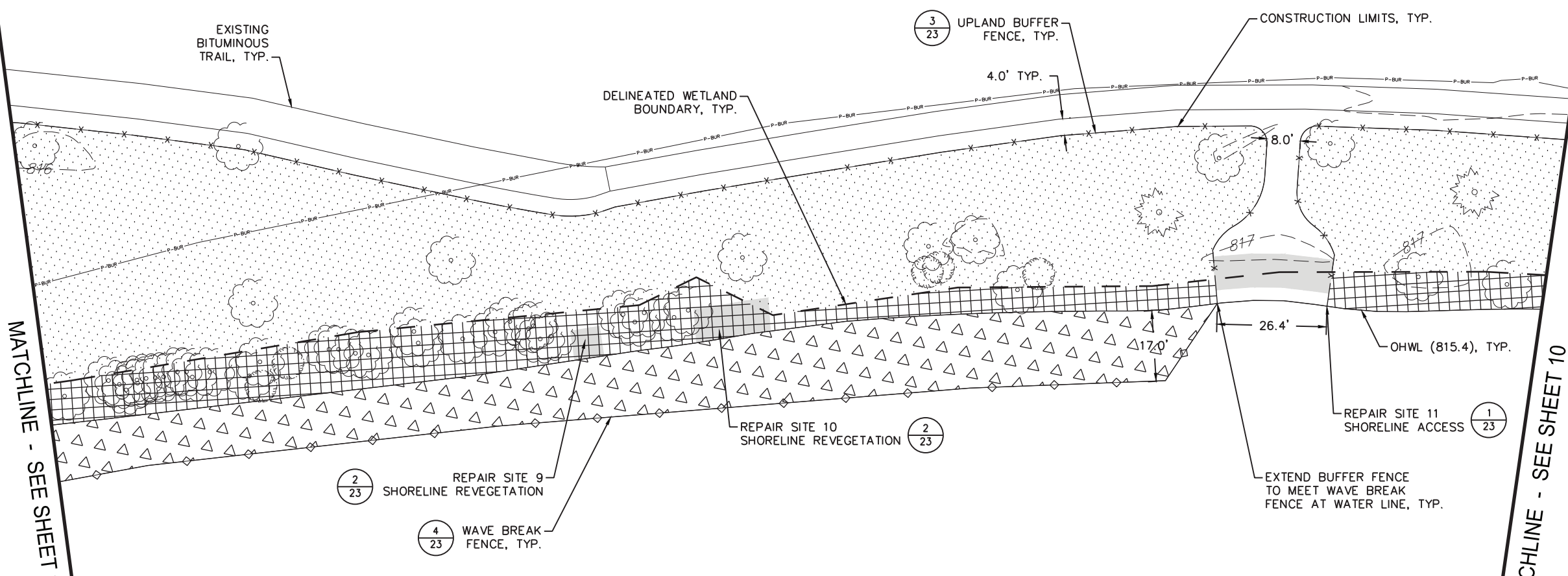

LEGEND	
	UPLAND BUFFER ZONE (SEED MIX 1) BWSR "LOW GROWING SOLAR ARRAY SOUTH & WEST" - MODIFIED
	SHORELINE ZONE (SEED MIX 2) MN STATE SEED MIX 34-261
	DELINEATED WETLAND BOUNDARY, TYP.
	100-YR FLOODPLAIN BOUNDARY (ELEV. 820.0)
	WAVE BREAK / FISH EXCLUSION FENCE (SEE DTL. 4/23)
	UPLAND BUFFER FENCE (SEE DTL. 3/23)
	EMERGENT ZONE SEE PLANT SCHEDULE
	LOW MAINT. TURF (SEED MIX 3) MN STATE SEED MIX 25-131
	EROSION CONTROL BLANKET CAT. 2 WITH SHORELINE ZONE SEED MIX
	TURF REINFORCEMENT MAT (TRM) CAT. 2
	EXISTING TREE

- NOTES:**
- ALL GENERAL NOTES FROM SHEET 2 SHALL APPLY.
 - REPORT ALL LAYOUT DISCREPANCIES IMMEDIATELY TO THE LANDSCAPE ARCHITECT FOR DIRECTION PRIOR TO PROCEEDING.
 - WRITTEN DIMENSIONS SHALL PREVAIL OVER DRAWING.
 - PROTECT ALL EXISTING VEGETATION NOT SCHEDULED FOR REMOVAL. ALL DISTURBED AREAS OUTSIDE OF THE CONSTRUCTION LIMITS SHALL BE REPAIRED TO EXISTING CONDITION BY THE CONTRACTOR.
 - ALL INVASIVE WOODY AND ALL INVASIVE HERBACEOUS VEGETATION WITHIN THE CONSTRUCTION LIMITS SHALL BE REMOVED BY THE CONTRACTOR. USE OF HERBICIDE SHALL COMPLY WITH MPRB REQUIREMENTS. SEE SPECIAL PROVISIONS FOR MORE INFORMATION.
 - VEGETATION REMOVAL AND SEEDBED PREPARATION PER MNDOT 2545. SEEDING PER MNDOT 2575. SEE SPECIAL PROVISIONS FOR MORE INFORMATION.
 - PROJECT SITE MUST BE KEPT CLEAN AND FREE OF DEBRIS.
 - CONTRACTOR SHALL STAKE ALL HERBICIDE, SEEDING, RIP RAP PLACEMENT, AND PLANTING LOCATIONS FOR APPROVAL BY ENGINEER PRIOR TO INSTALLATION.
 - SEE PLANT SCHEDULE ON SHEET 21.
 - REFER TO PROJECT SPECIFICATIONS FOR ADDITIONAL REQUIREMENTS.

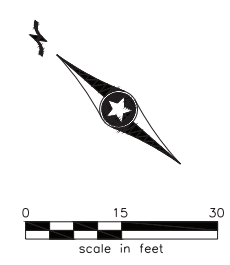

SEAN JERGENS 10/13/2018 8:05:46 AM H:\PROJECTS\10000\10547\CAD_BIM\PLAN\10547_LAN.DWG: 008

NO	DATE	BY	CKD	APPR

I hereby certify that this plan, specification, or report was prepared by me or under my direct supervision and that I am a duly Licensed Professional Landscape Architect under the laws of the State of Minnesota.
 Print Name: SEAN JERGENS
 Date: OCTOBER 12, 2018 License # _____

DRAWN BY R. BURAND
 DESIGNED BY S. JERGENS
 CHECKED BY S. JERGENS
 COMM. NO. 10547



MINNEAPOLIS PARK & RECREATION BOARD
 LANDSCAPE PLANS
 LAKE NOKOMIS SHORELINE ENHANCEMENT

SHEET 9 OF 35

MATCHLINE - SEE SHEET 9

MATCHLINE - SEE SHEET 11

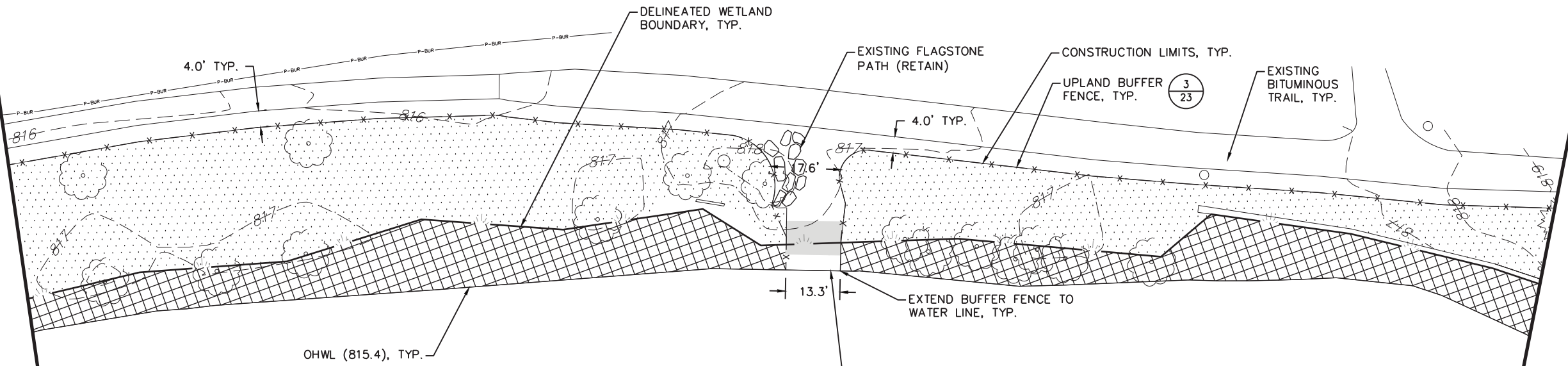

LEGEND	
	UPLAND BUFFER ZONE (SEED MIX 1) BWSR "LOW GROWING SOLAR ARRAY SOUTH & WEST" - MODIFIED
	SHORELINE ZONE (SEED MIX 2) MN STATE SEED MIX 34-261
	DELINEATED WETLAND BOUNDARY, TYP.
	100-YR FLOODPLAIN BOUNDARY (ELEV. 820.0)
	WAVE BREAK / FISH EXCLUSION FENCE (SEE DTL. 4/23)
	UPLAND BUFFER FENCE (SEE DTL. 3/23)
	EMERGENT ZONE SEE PLANT SCHEDULE
	LOW MAINT. TURF (SEED MIX 3) MN STATE SEED MIX 25-131
	EROSION CONTROL BLANKET CAT. 2 WITH SHORELINE ZONE SEED MIX
	TURF REINFORCEMENT MAT (TRM) CAT. 2
	EXISTING TREE

- NOTES:
1. ALL GENERAL NOTES FROM SHEET 2 SHALL APPLY.
 2. REPORT ALL LAYOUT DISCREPANCIES IMMEDIATELY TO THE LANDSCAPE ARCHITECT FOR DIRECTION PRIOR TO PROCEEDING.
 3. WRITTEN DIMENSIONS SHALL PREVAIL OVER DRAWING.
 4. PROTECT ALL EXISTING VEGETATION NOT SCHEDULED FOR REMOVAL. ALL DISTURBED AREAS OUTSIDE OF THE CONSTRUCTION LIMITS SHALL BE REPAIRED TO EXISTING CONDITION BY THE CONTRACTOR.
 5. ALL INVASIVE WOODY AND ALL INVASIVE HERBACEOUS VEGETATION WITHIN THE CONSTRUCTION LIMITS SHALL BE REMOVED BY THE CONTRACTOR. USE OF HERBICIDE SHALL COMPLY WITH MPRB REQUIREMENTS. SEE SPECIAL PROVISIONS FOR MORE INFORMATION.
 6. VEGETATION REMOVAL AND SEEDBED PREPARATION PER MNDOT 2545. SEEDING PER MNDOT 2575. SEE SPECIAL PROVISIONS FOR MORE INFORMATION.
 7. PROJECT SITE MUST BE KEPT CLEAN AND FREE OF DEBRIS.
 8. CONTRACTOR SHALL STAKE ALL HERBICIDE, SEEDING, RIP RAP PLACEMENT, AND PLANTING LOCATIONS FOR APPROVAL BY ENGINEER PRIOR TO INSTALLATION.
 9. SEE PLANT SCHEDULE ON SHEET 21.
 10. REFER TO PROJECT SPECIFICATIONS FOR ADDITIONAL REQUIREMENTS.

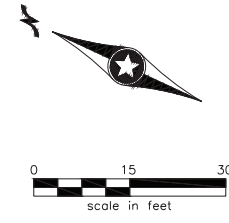

SEAN_JERGENS.dwg | 10/13/2018 8:05:46 AM
 H:\PROJECTS\10000\10547\CAD_BIM\PLAN\10547_LAN.DWG: 009

NO	DATE	BY	CHKD	APPR

I hereby certify that this plan, specification, or report was prepared by me or under my direct supervision and that I am a duly Licensed Professional Landscape Architect under the laws of the State of Minnesota.
 Print Name: SEAN JERGENS
 Date: OCTOBER 12, 2018 License # _____

DRAWN BY: R. BURAND
 DESIGNED BY: S. JERGENS
 CHECKED BY: S. JERGENS
 COMM. NO. 10547



MINNEAPOLIS PARK & RECREATION BOARD
 LANDSCAPE PLANS
 LAKE NOKOMIS SHORELINE ENHANCEMENT







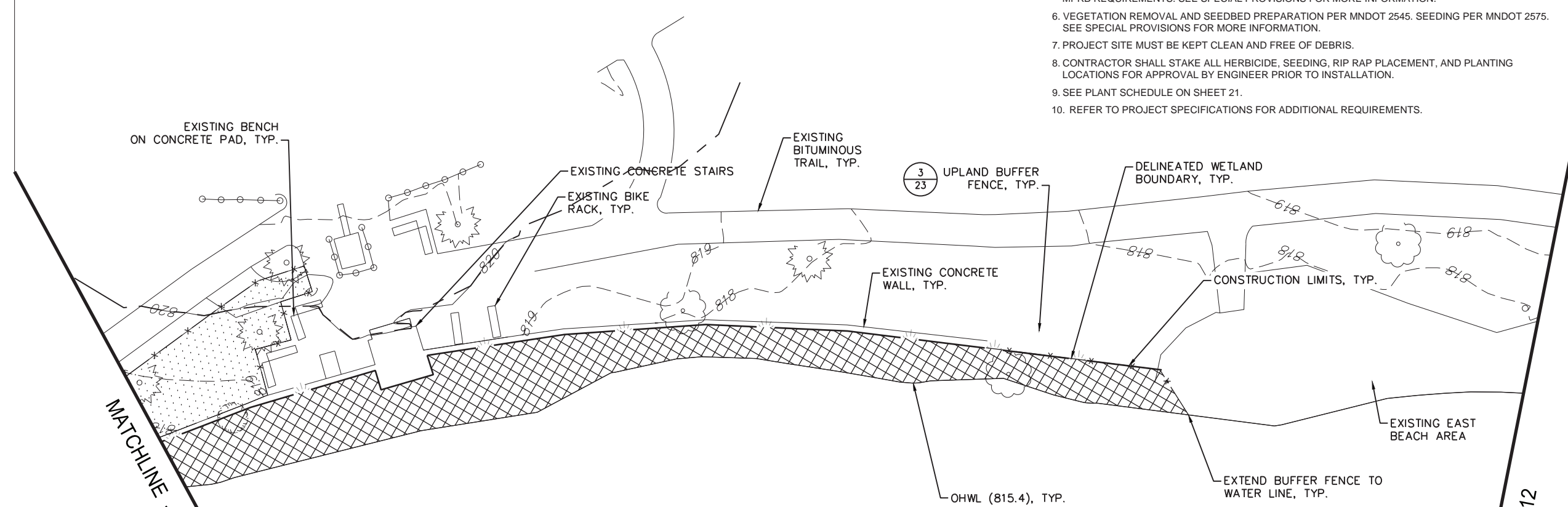

SHEET 10 OF 35

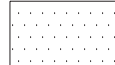
NOTES:

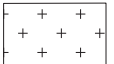
1. ALL GENERAL NOTES FROM SHEET 2 SHALL APPLY.
2. REPORT ALL LAYOUT DISCREPANCIES IMMEDIATELY TO THE LANDSCAPE ARCHITECT FOR DIRECTION PRIOR TO PROCEEDING.
3. WRITTEN DIMENSIONS SHALL PREVAIL OVER DRAWING.
4. PROTECT ALL EXISTING VEGETATION NOT SCHEDULED FOR REMOVAL. ALL DISTURBED AREAS OUTSIDE OF THE CONSTRUCTION LIMITS SHALL BE REPAIRED TO EXISTING CONDITION BY THE CONTRACTOR.
5. ALL INVASIVE WOODY AND ALL INVASIVE HERBACEOUS VEGETATION WITHIN THE CONSTRUCTION LIMITS SHALL BE REMOVED BY THE CONTRACTOR. USE OF HERBICIDE SHALL COMPLY WITH MPRB REQUIREMENTS. SEE SPECIAL PROVISIONS FOR MORE INFORMATION.
6. VEGETATION REMOVAL AND SEEDBED PREPARATION PER MNDOT 2545. SEEDING PER MNDOT 2575. SEE SPECIAL PROVISIONS FOR MORE INFORMATION.
7. PROJECT SITE MUST BE KEPT CLEAN AND FREE OF DEBRIS.
8. CONTRACTOR SHALL STAKE ALL HERBICIDE, SEEDING, RIP RAP PLACEMENT, AND PLANTING LOCATIONS FOR APPROVAL BY ENGINEER PRIOR TO INSTALLATION.
9. SEE PLANT SCHEDULE ON SHEET 21.
10. REFER TO PROJECT SPECIFICATIONS FOR ADDITIONAL REQUIREMENTS.

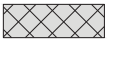

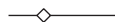
LEGEND

	UPLAND BUFFER ZONE (SEED MIX 1) BWSR "LOW GROWING SOLAR ARRAY SOUTH & WEST" - MODIFIED		EMERGENT ZONE SEE PLANT SCHEDULE
	SHORELINE ZONE (SEED MIX 2) MN STATE SEED MIX 34-261		LOW MAINT. TURF (SEED MIX 3) MN STATE SEED MIX 25-131
	DELINEATED WETLAND BOUNDARY, TYP.		EROSION CONTROL BLANKET CAT. 2 WITH SHORELINE ZONE SEED MIX
	100-YR FLOODPLAIN BOUNDARY (ELEV. 820.0)		TURF REINFORCEMENT MAT (TRM) CAT. 2
	WAVE BREAK / FISH EXCLUSION FENCE (SEE DTL. 4/23)		EXISTING TREE
	UPLAND BUFFER FENCE (SEE DTL. 3/23)		

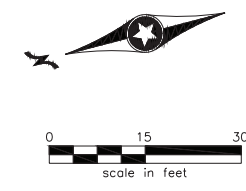

SEAN_JERGENS 10/13/2018 8:05:46 AM
 H:\PROJECTS\10000\10547\CAD_BIM\PLAN\10547_LAN.DWG: 010

NO	DATE	BY	CHKD	APPR

I hereby certify that this plan, specification, or report was prepared by me or under my direct supervision and that I am a duly Licensed Professional Landscape Architect under the laws of the State of Minnesota.
 Print Name: SEAN JERGENS
 Date: OCTOBER 12, 2018 License # #####

CITY PROJECT NO. ##
 DRAWN BY: R. BURAND
 DESIGNED BY: S. JERGENS
 CHECKED BY: S. JERGENS
 COMM. NO. 10547



MINNEAPOLIS PARK & RECREATION BOARD
 LANDSCAPE PLANS
 LAKE NOKOMIS SHORELINE ENHANCEMENT

SHEET
 11
 OF
 35

MATCHLINE - SEE SHEET 11

MATCHLINE - SEE SHEET 13

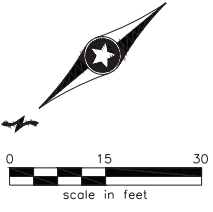

LEGEND	
	UPLAND BUFFER ZONE (SEED MIX 1) BWSR "LOW GROWING SOLAR ARRAY SOUTH & WEST" - MODIFIED
	SHORELINE ZONE (SEED MIX 2) MN STATE SEED MIX 34-261
	DELINEATED WETLAND BOUNDARY, TYP.
	100-YR FLOODPLAIN BOUNDARY (ELEV. 820.0)
	WAVE BREAK / FISH EXCLUSION FENCE (SEE DTL. 4/23)
	UPLAND BUFFER FENCE (SEE DTL. 3/23)
	EMERGENT ZONE SEE PLANT SCHEDULE
	LOW MAINT. TURF (SEED MIX 3) MN STATE SEED MIX 25-131
	EROSION CONTROL BLANKET CAT. 2 WITH SHORELINE ZONE SEED MIX
	TURF REINFORCEMENT MAT (TRM) CAT. 2
	EXISTING TREE

- NOTES:**
1. ALL GENERAL NOTES FROM SHEET 2 SHALL APPLY.
 2. REPORT ALL LAYOUT DISCREPANCIES IMMEDIATELY TO THE LANDSCAPE ARCHITECT FOR DIRECTION PRIOR TO PROCEEDING.
 3. WRITTEN DIMENSIONS SHALL PREVAIL OVER DRAWING.
 4. PROTECT ALL EXISTING VEGETATION NOT SCHEDULED FOR REMOVAL. ALL DISTURBED AREAS OUTSIDE OF THE CONSTRUCTION LIMITS SHALL BE REPAIRED TO EXISTING CONDITION BY THE CONTRACTOR.
 5. ALL INVASIVE WOODY AND ALL INVASIVE HERBACEOUS VEGETATION WITHIN THE CONSTRUCTION LIMITS SHALL BE REMOVED BY THE CONTRACTOR. USE OF HERBICIDE SHALL COMPLY WITH MPRB REQUIREMENTS. SEE SPECIAL PROVISIONS FOR MORE INFORMATION.
 6. VEGETATION REMOVAL AND SEEDBED PREPARATION PER MNDOT 2545. SEEDING PER MNDOT 2575. SEE SPECIAL PROVISIONS FOR MORE INFORMATION.
 7. PROJECT SITE MUST BE KEPT CLEAN AND FREE OF DEBRIS.
 8. CONTRACTOR SHALL STAKE ALL HERBICIDE, SEEDING, RIP RAP PLACEMENT, AND PLANTING LOCATIONS FOR APPROVAL BY ENGINEER PRIOR TO INSTALLATION.
 9. SEE PLANT SCHEDULE ON SHEET 21.
 10. REFER TO PROJECT SPECIFICATIONS FOR ADDITIONAL REQUIREMENTS.

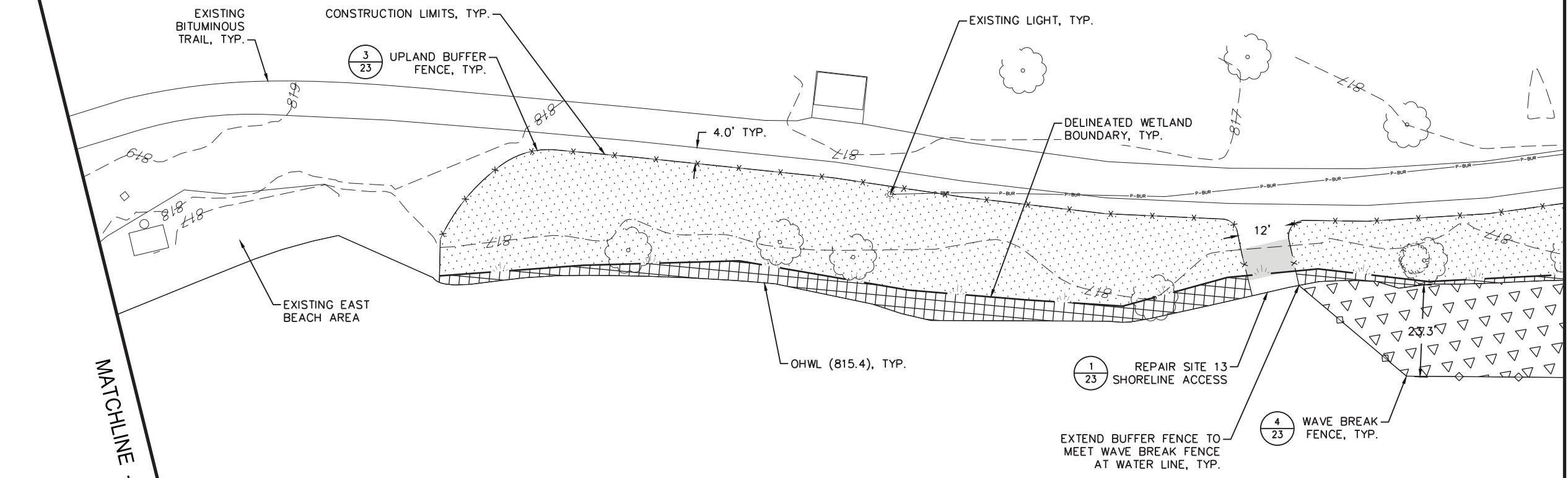

SEAN JERGENS 10/13/2018 8:05:46 AM H:\PROJECTS\10000\10547\CAD_BIM\PLAN\10547_LAN.DWG: 011

NO	DATE	BY	CKD	APPR

I hereby certify that this plan, specification, or report was prepared by me or under my direct supervision and that I am a duly Licensed Professional Landscape Architect under the laws of the State of Minnesota.

Print Name: SEAN JERGENS

Date: OCTOBER 12, 2018 License # _____

DRAWN BY: R. BURAND
 DESIGNED BY: S. JERGENS
 CHECKED BY: S. JERGENS
 COMM. NO. 10547



MINNEAPOLIS PARK & RECREATION BOARD
 LANDSCAPE PLANS
 LAKE NOKOMIS SHORELINE ENHANCEMENT

SHEET 12 OF 35

MATCHLINE - SEE SHEET 12

MATCHLINE - SEE SHEET 14

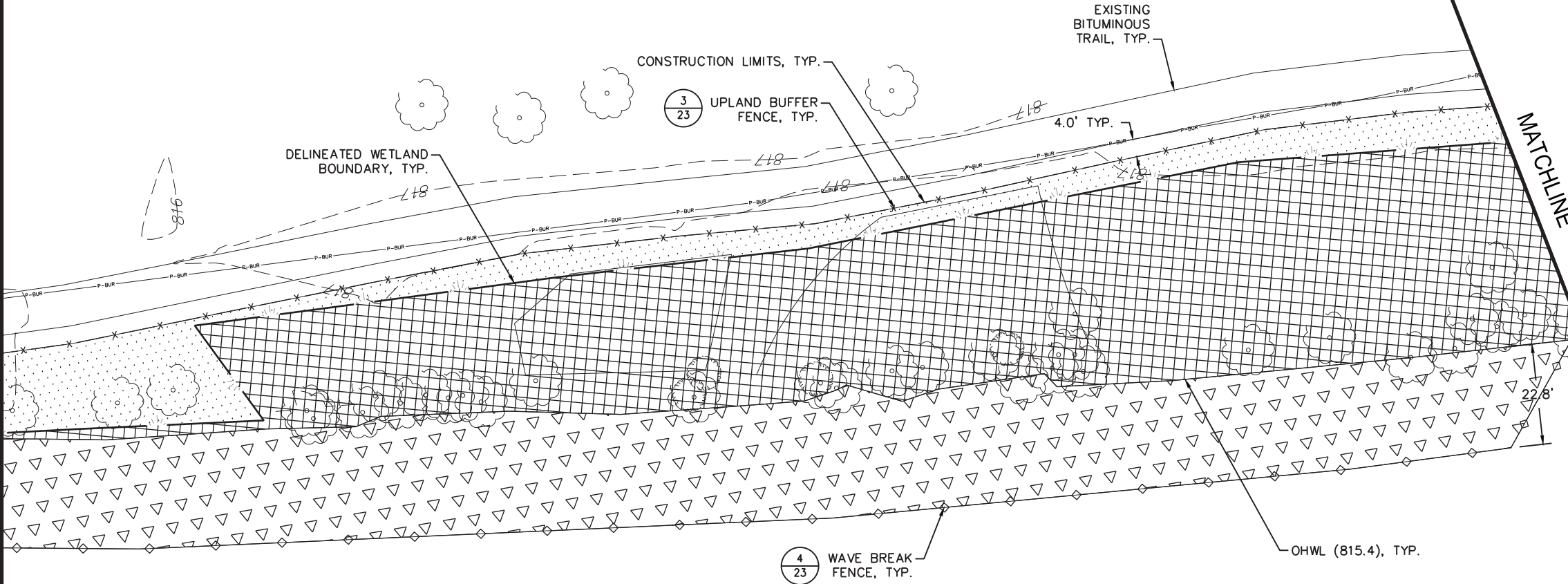

LEGEND	
	UPLAND BUFFER ZONE (SEED MIX 1) BWSR "LOW GROWING SOLAR ARRAY SOUTH & WEST" - MODIFIED
	SHORELINE ZONE (SEED MIX 2) MN STATE SEED MIX 34-261
	DELINEATED WETLAND BOUNDARY, TYP.
	100-YR FLOODPLAIN BOUNDARY (ELEV. 820.0)
	WAVE BREAK / FISH EXCLUSION FENCE (SEE DTL. 4/23)
	UPLAND BUFFER FENCE (SEE DTL. 3/23)
	EMERGENT ZONE SEE PLANT SCHEDULE
	LOW MAINT. TURF (SEED MIX 3) MN STATE SEED MIX 25-131
	EROSION CONTROL BLANKET CAT. 2 WITH SHORELINE ZONE SEED MIX
	TURF REINFORCEMENT MAT (TRM) CAT. 2
	EXISTING TREE

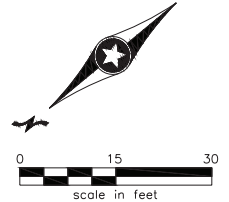

- NOTES:**
1. ALL GENERAL NOTES FROM SHEET 2 SHALL APPLY.
 2. REPORT ALL LAYOUT DISCREPANCIES IMMEDIATELY TO THE LANDSCAPE ARCHITECT FOR DIRECTION PRIOR TO PROCEEDING.
 3. WRITTEN DIMENSIONS SHALL PREVAIL OVER DRAWING.
 4. PROTECT ALL EXISTING VEGETATION NOT SCHEDULED FOR REMOVAL. ALL DISTURBED AREAS OUTSIDE OF THE CONSTRUCTION LIMITS SHALL BE REPAIRED TO EXISTING CONDITION BY THE CONTRACTOR.
 5. ALL INVASIVE WOODY AND ALL INVASIVE HERBACEOUS VEGETATION WITHIN THE CONSTRUCTION LIMITS SHALL BE REMOVED BY THE CONTRACTOR. USE OF HERBICIDE SHALL COMPLY WITH MPRB REQUIREMENTS. SEE SPECIAL PROVISIONS FOR MORE INFORMATION.
 6. VEGETATION REMOVAL AND SEEDBED PREPARATION PER MNDOT 2545. SEEDING PER MNDOT 2575. SEE SPECIAL PROVISIONS FOR MORE INFORMATION.
 7. PROJECT SITE MUST BE KEPT CLEAN AND FREE OF DEBRIS.
 8. CONTRACTOR SHALL STAKE ALL HERBICIDE, SEEDING, RIP RAP PLACEMENT, AND PLANTING LOCATIONS FOR APPROVAL BY ENGINEER PRIOR TO INSTALLATION.
 9. SEE PLANT SCHEDULE ON SHEET 21.
 10. REFER TO PROJECT SPECIFICATIONS FOR ADDITIONAL REQUIREMENTS.

SEAN_JERGENS.dwg | 10/13/2018 8:05:46 AM
 H:\PROJECTS\10000\10547\CAD_BIM\PLAN\10547_LAN.DWG: 012

NO	DATE	BY	CKD	APPR

I hereby certify that this plan, specification, or report was prepared by me or under my direct supervision and that I am a duly Licensed Professional Landscape Architect under the laws of the State of Minnesota.
 Print Name: SEAN JERGENS
 Date: OCTOBER 12, 2018 License # _____ CITY PROJECT NO. ##

DRAWN BY: R. BURAND
 DESIGNED BY: S. JERGENS
 CHECKED BY: S. JERGENS
 COMM. NO. 10547



MINNEAPOLIS PARK & RECREATION BOARD
 LANDSCAPE PLANS
 LAKE NOKOMIS SHORELINE ENHANCEMENT

SHEET 13 OF 35

MATCHLINE - SEE SHEET 13

MATCHLINE - SEE SHEET 15

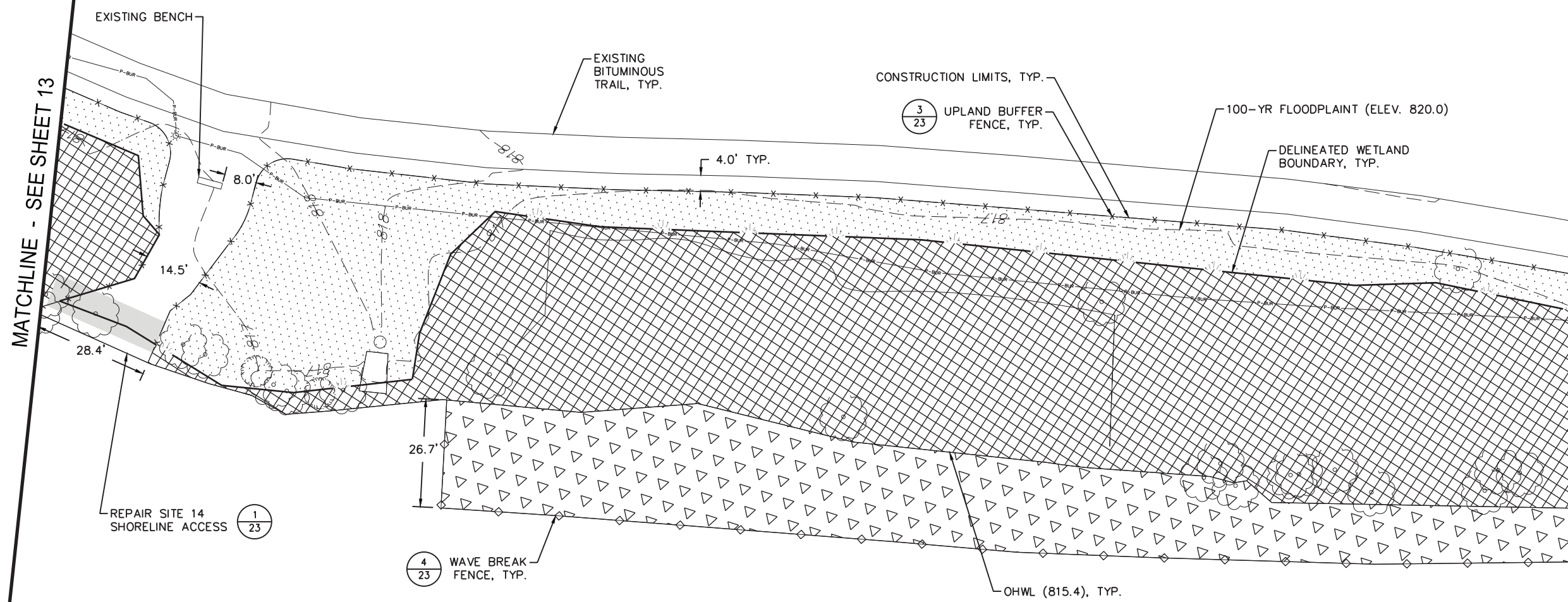

LEGEND	
	UPLAND BUFFER ZONE (SEED MIX 1) BWSR "LOW GROWING SOLAR ARRAY SOUTH & WEST" - MODIFIED
	SHORELINE ZONE (SEED MIX 2) MN STATE SEED MIX 34-261
	DELINEATED WETLAND BOUNDARY, TYP.
	100-YR FLOODPLAIN BOUNDARY (ELEV. 820.0)
	WAVE BREAK / FISH EXCLUSION FENCE (SEE DTL. 4/23)
	UPLAND BUFFER FENCE (SEE DTL. 3/23)
	EMERGENT ZONE SEE PLANT SCHEDULE
	LOW MAINT. TURF (SEED MIX 3) MN STATE SEED MIX 25-131
	EROSION CONTROL BLANKET CAT. 2 WITH SHORELINE ZONE SEED MIX
	TURF REINFORCEMENT MAT (TRM) CAT. 2
	EXISTING TREE

- NOTES:**
1. ALL GENERAL NOTES FROM SHEET 2 SHALL APPLY.
 2. REPORT ALL LAYOUT DISCREPANCIES IMMEDIATELY TO THE LANDSCAPE ARCHITECT FOR DIRECTION PRIOR TO PROCEEDING.
 3. WRITTEN DIMENSIONS SHALL PREVAIL OVER DRAWING.
 4. PROTECT ALL EXISTING VEGETATION NOT SCHEDULED FOR REMOVAL. ALL DISTURBED AREAS OUTSIDE OF THE CONSTRUCTION LIMITS SHALL BE REPAIRED TO EXISTING CONDITION BY THE CONTRACTOR.
 5. ALL INVASIVE WOODY AND ALL INVASIVE HERBACEOUS VEGETATION WITHIN THE CONSTRUCTION LIMITS SHALL BE REMOVED BY THE CONTRACTOR. USE OF HERBICIDE SHALL COMPLY WITH MPRB REQUIREMENTS. SEE SPECIAL PROVISIONS FOR MORE INFORMATION.
 6. VEGETATION REMOVAL AND SEEDBED PREPARATION PER MNDOT 2545. SEEDING PER MNDOT 2575. SEE SPECIAL PROVISIONS FOR MORE INFORMATION.
 7. PROJECT SITE MUST BE KEPT CLEAN AND FREE OF DEBRIS.
 8. CONTRACTOR SHALL STAKE ALL HERBICIDE, SEEDING, RIP RAP PLACEMENT, AND PLANTING LOCATIONS FOR APPROVAL BY ENGINEER PRIOR TO INSTALLATION.
 9. SEE PLANT SCHEDULE ON SHEET 21.
 10. REFER TO PROJECT SPECIFICATIONS FOR ADDITIONAL REQUIREMENTS.

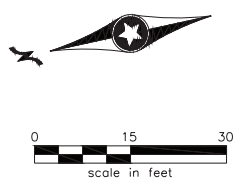

SEAN_JERGENS 10/13/2018 8:05:46 AM
 H:\PROJECTS\10000\10547\CAD_BIM\PLAN\10547_LAN.DWG: 013

NO	DATE	BY	CHKD	APPR

I hereby certify that this plan, specification, or report was prepared by me or under my direct supervision and that I am a duly Licensed Professional Landscape Architect under the laws of the State of Minnesota.
 Print Name: SEAN JERGENS
 Date: OCTOBER 12, 2018 License # #####

DRAWN BY: R. BURAND
 DESIGNED BY: S. JERGENS
 CHECKED BY: S. JERGENS
 COMM. NO. 10547



MINNEAPOLIS PARK & RECREATION BOARD
 LANDSCAPE PLANS
 LAKE NOKOMIS SHORELINE ENHANCEMENT

SHEET 14 OF 35

NOTES:

1. ALL GENERAL NOTES FROM SHEET 2 SHALL APPLY.
2. REPORT ALL LAYOUT DISCREPANCIES IMMEDIATELY TO THE LANDSCAPE ARCHITECT FOR DIRECTION PRIOR TO PROCEEDING.
3. WRITTEN DIMENSIONS SHALL PREVAIL OVER DRAWING.
4. PROTECT ALL EXISTING VEGETATION NOT SCHEDULED FOR REMOVAL. ALL DISTURBED AREAS OUTSIDE OF THE CONSTRUCTION LIMITS SHALL BE REPAIRED TO EXISTING CONDITION BY THE CONTRACTOR.
5. ALL INVASIVE WOODY AND ALL INVASIVE HERBACEOUS VEGETATION WITHIN THE CONSTRUCTION LIMITS SHALL BE REMOVED BY THE CONTRACTOR. USE OF HERBICIDE SHALL COMPLY WITH MPRB REQUIREMENTS. SEE SPECIAL PROVISIONS FOR MORE INFORMATION.
6. VEGETATION REMOVAL AND SEEDBED PREPARATION PER MNDOT 2545. SEEDING PER MNDOT 2575. SEE SPECIAL PROVISIONS FOR MORE INFORMATION.
7. PROJECT SITE MUST BE KEPT CLEAN AND FREE OF DEBRIS.
8. CONTRACTOR SHALL STAKE ALL HERBICIDE, SEEDING, RIP RAP PLACEMENT, AND PLANTING LOCATIONS FOR APPROVAL BY ENGINEER PRIOR TO INSTALLATION.
9. SEE PLANT SCHEDULE ON SHEET 21.
10. REFER TO PROJECT SPECIFICATIONS FOR ADDITIONAL REQUIREMENTS.

MATCHLINE - SEE SHEET 14

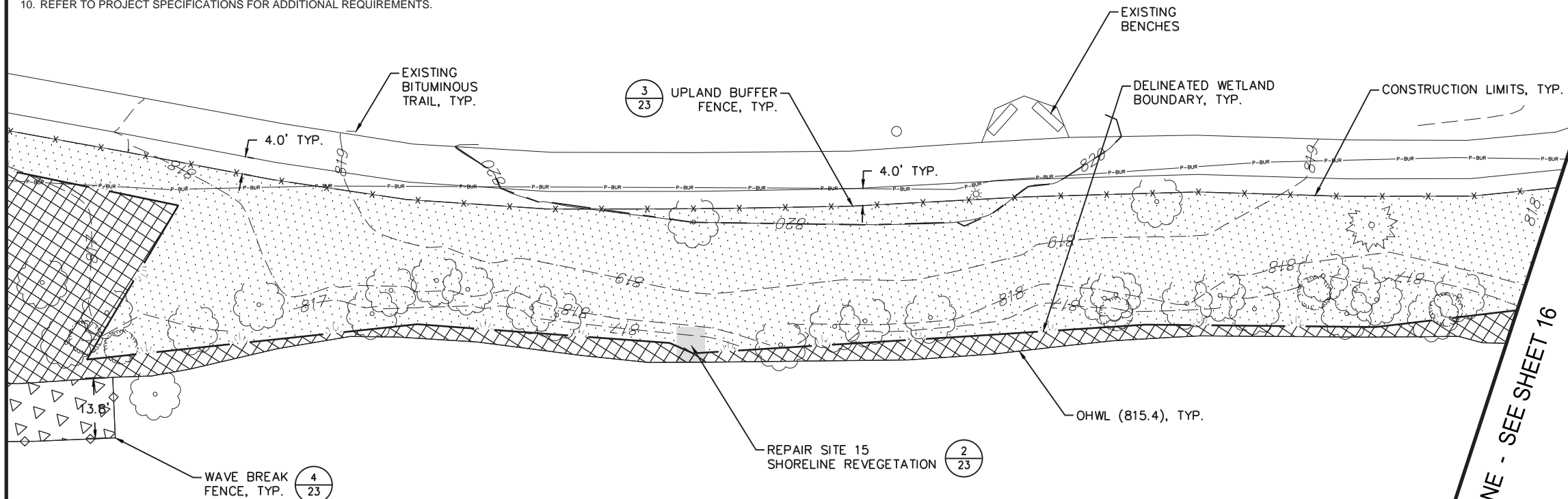

MATCHLINE - SEE SHEET 16

LEGEND	
	UPLAND BUFFER ZONE (SEED MIX 1) BWSR "LOW GROWING SOLAR ARRAY SOUTH & WEST" - MODIFIED
	SHORELINE ZONE (SEED MIX 2) MN STATE SEED MIX 34-261
	DELINEATED WETLAND BOUNDARY, TYP.
	100-YR FLOODPLAIN BOUNDARY (ELEV. 820.0)
	WAVE BREAK / FISH EXCLUSION FENCE (SEE DTL. 4/23)
	UPLAND BUFFER FENCE (SEE DTL. 3/23)
	EMERGENT ZONE SEE PLANT SCHEDULE
	LOW MAINT. TURF (SEED MIX 3) MN STATE SEED MIX 25-131
	EROSION CONTROL BLANKET CAT. 2 WITH SHORELINE ZONE SEED MIX
	TURF REINFORCEMENT MAT (TRM) CAT. 2
	EXISTING TREE

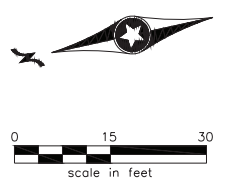

SEAN_JERGENS.dwg | 10/13/2018 8:05:46 AM | H:\PROJECTS\10000\10547\CAD_BIM\PLAN\10547_LAN.DWG: 014

NO	DATE	BY	CKD	APPR

I hereby certify that this plan, specification, or report was prepared by me or under my direct supervision and that I am a duly Licensed Professional Landscape Architect under the laws of the State of Minnesota.
 Print Name: SEAN JERGENS
 Date: OCTOBER 12, 2018 License # _____

CITY PROJECT NO. ##
 DRAWN BY: R. BURAND
 DESIGNED BY: S. JERGENS
 CHECKED BY: S. JERGENS
 COMM. NO. 10547



MINNEAPOLIS PARK & RECREATION BOARD
 LANDSCAPE PLANS
 LAKE NOKOMIS SHORELINE ENHANCEMENT

SHEET
 15
 OF
 35

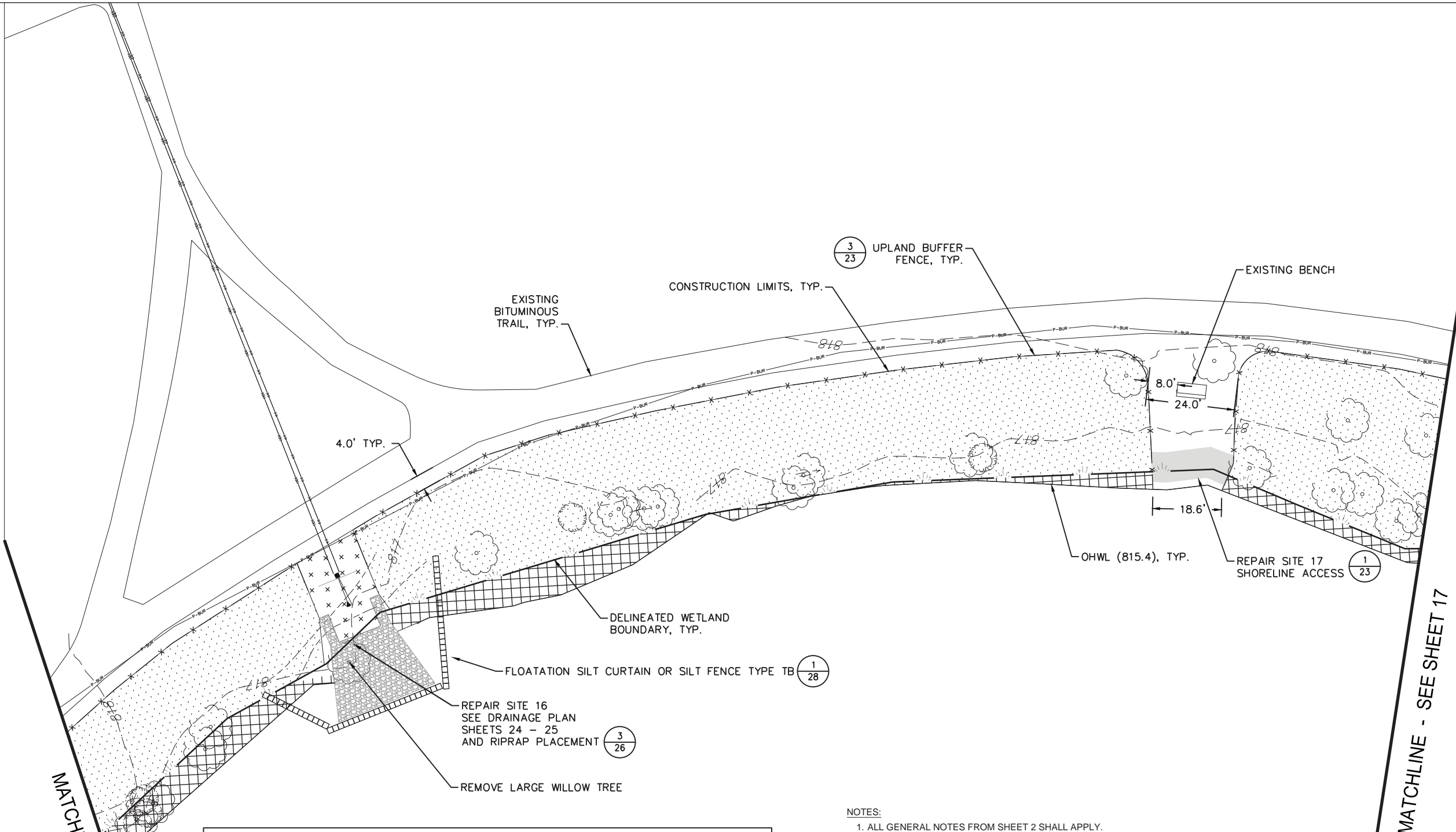

LEGEND	
	UPLAND BUFFER ZONE (SEED MIX 1) BWSR "LOW GROWING SOLAR ARRAY SOUTH & WEST" - MODIFIED
	SHORELINE ZONE (SEED MIX 2) MN STATE SEED MIX 34-261
	DELINEATED WETLAND BOUNDARY, TYP.
	100-YR FLOODPLAIN BOUNDARY (ELEV. 820.0)
	WAVE BREAK / FISH EXCLUSION FENCE (SEE DTL. 4/23)
	UPLAND BUFFER FENCE (SEE DTL. 3/23)
	EMERGENT ZONE SEE PLANT SCHEDULE
	LOW MAINT. TURF (SEED MIX 3) MN STATE SEED MIX 25-131
	EROSION CONTROL BLANKET CAT. 2 WITH SHORELINE ZONE SEED MIX
	TURF REINFORCEMENT MAT (TRM) CAT. 2
	EXISTING TREE

- NOTES:
1. ALL GENERAL NOTES FROM SHEET 2 SHALL APPLY.
 2. REPORT ALL LAYOUT DISCREPANCIES IMMEDIATELY TO THE LANDSCAPE ARCHITECT FOR DIRECTION PRIOR TO PROCEEDING.
 3. WRITTEN DIMENSIONS SHALL PREVAIL OVER DRAWING.
 4. PROTECT ALL EXISTING VEGETATION NOT SCHEDULED FOR REMOVAL. ALL DISTURBED AREAS OUTSIDE OF THE CONSTRUCTION LIMITS SHALL BE REPAIRED TO EXISTING CONDITION BY THE CONTRACTOR.
 5. ALL INVASIVE WOODY AND ALL INVASIVE HERBACEOUS VEGETATION WITHIN THE CONSTRUCTION LIMITS SHALL BE REMOVED BY THE CONTRACTOR. USE OF HERBICIDE SHALL COMPLY WITH MPRB REQUIREMENTS. SEE SPECIAL PROVISIONS FOR MORE INFORMATION.
 6. VEGETATION REMOVAL AND SEEDBED PREPARATION PER MNDOT 2545. SEEDING PER MNDOT 2575. SEE SPECIAL PROVISIONS FOR MORE INFORMATION.
 7. PROJECT SITE MUST BE KEPT CLEAN AND FREE OF DEBRIS.
 8. CONTRACTOR SHALL STAKE ALL HERBICIDE, SEEDING, RIP RAP PLACEMENT, AND PLANTING LOCATIONS FOR APPROVAL BY ENGINEER PRIOR TO INSTALLATION.
 9. SEE PLANT SCHEDULE ON SHEET 21.
 10. REFER TO PROJECT SPECIFICATIONS FOR ADDITIONAL REQUIREMENTS.

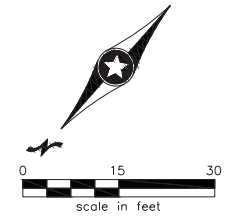

MATCHLINE - SEE SHEET 15

MATCHLINE - SEE SHEET 17

SEAN_JERGENS 10/13/2018 8:05:46 AM H:\PROJECTS\10000\10547\CAD_BIM\PLAN\10547_LAN.DWG: 015

NO	DATE	BY	CHKD	APPR

I hereby certify that this plan, specification, or report was prepared by me or under my direct supervision and that I am a duly Licensed Professional Landscape Architect under the laws of the State of Minnesota.
 Print Name: SEAN JERGENS
 Date: OCTOBER 12, 2018 License # _____

DRAWN BY: R. BURAND
 DESIGNED BY: S. JERGENS
 CHECKED BY: S. JERGENS
 COMM. NO. 10547



MINNEAPOLIS PARK & RECREATION BOARD
 LANDSCAPE PLANS
 LAKE NOKOMIS SHORELINE ENHANCEMENT

SHEET 16 OF 35

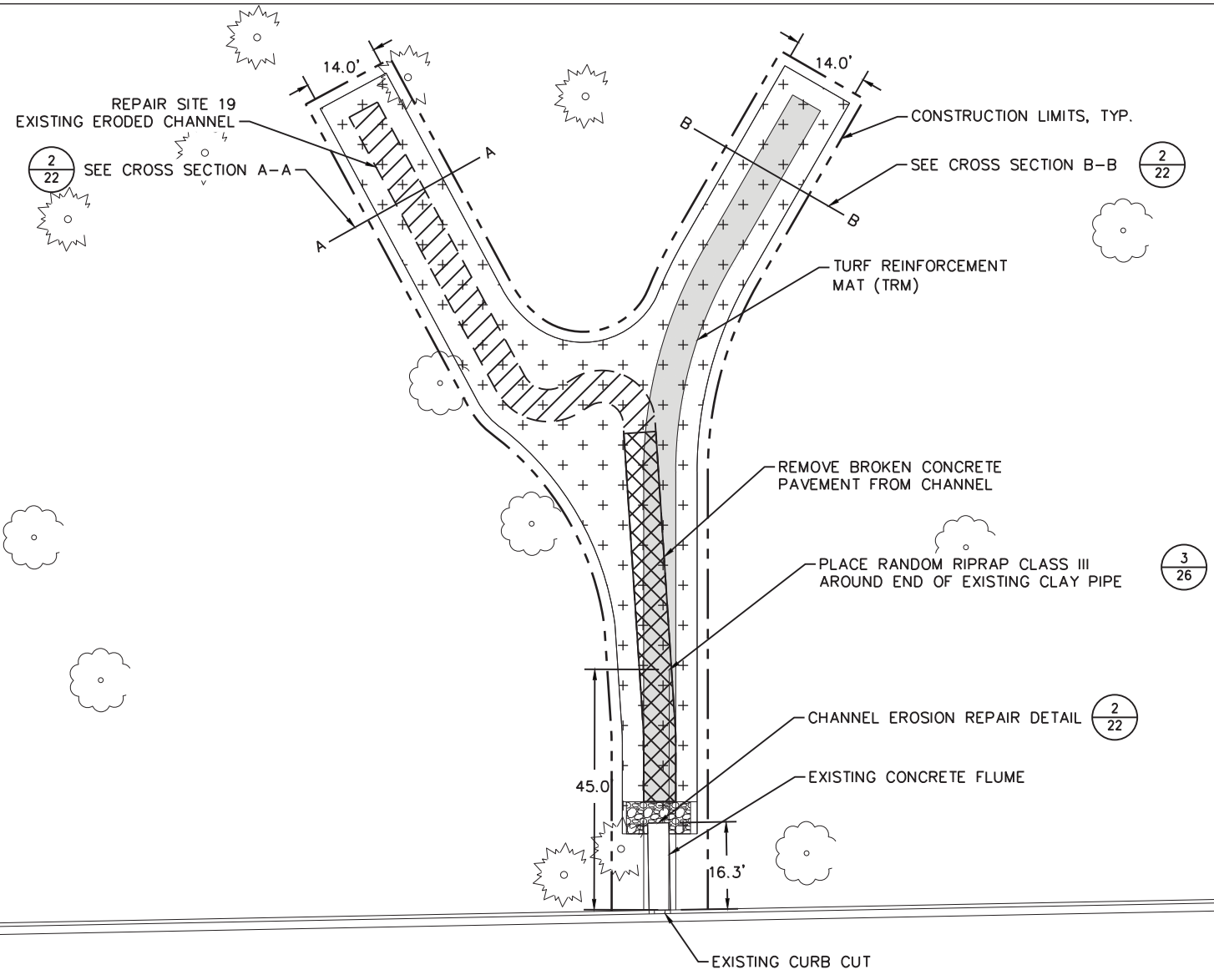

WOODLAWN BLVD

S 19TH AVE

NOTES:

1. ALL GENERAL NOTES FROM SHEET 2 SHALL APPLY.
2. REPORT ALL LAYOUT DISCREPANCIES IMMEDIATELY TO THE LANDSCAPE ARCHITECT FOR DIRECTION PRIOR TO PROCEEDING.
3. WRITTEN DIMENSIONS SHALL PREVAIL OVER DRAWING.
4. PROTECT ALL EXISTING VEGETATION NOT SCHEDULED FOR REMOVAL. ALL DISTURBED AREAS OUTSIDE OF THE CONSTRUCTION LIMITS SHALL BE REPAIRED TO EXISTING CONDITION BY THE CONTRACTOR.
5. ALL INVASIVE WOODY AND ALL INVASIVE HERBACEOUS VEGETATION WITHIN THE CONSTRUCTION LIMITS SHALL BE REMOVED BY THE CONTRACTOR. USE OF HERBICIDE SHALL COMPLY WITH MPRB REQUIREMENTS. SEE SPECIAL PROVISIONS FOR MORE INFORMATION.
6. VEGETATION REMOVAL AND SEEDBED PREPARATION PER MNDOT 2545. SEEDING PER MNDOT 2575. SEE SPECIAL PROVISIONS FOR MORE INFORMATION.
7. PROJECT SITE MUST BE KEPT CLEAN AND FREE OF DEBRIS.
8. CONTRACTOR SHALL STAKE ALL HERBICIDE, SEEDING, RIP RAP PLACEMENT, AND PLANTING LOCATIONS FOR APPROVAL BY ENGINEER PRIOR TO INSTALLATION.
9. SEE PLANT SCHEDULE ON SHEET 21.
10. REFER TO PROJECT SPECIFICATIONS FOR ADDITIONAL REQUIREMENTS.

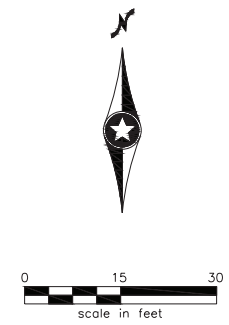

LEGEND	
	LOW MAINT. TURF (SEED MIX 3) MN STATE SEED MIX 25-131
	EXISTING ERODED CHANNEL
	EXISTING TREE
	CONSTRUCTION LIMITS
	REMOVE CONC. PAVEMENT FROM CHANNEL
	FILL CHANNEL WITH TOPSOIL
	TURF REINFORCEMENT MAT (TRM) CATEGORY 2
	RIP RAP CLASS 3

I hereby certify that this plan, specification, or report was prepared by me or under my direct supervision and that I am a duly Licensed Professional Landscape Architect under the laws of the State of Minnesota.
 Print Name: SEAN JERGENS
 Date OCTOBER 12, 2018 License # #####

DRAWN BY R. BURAND
 DESIGNED BY S. JERGENS
 CHECKED BY S. JERGENS
 COMM. NO. 10547



MINNEAPOLIS PARK & RECREATION BOARD
 LANDSCAPE PLANS
 LAKE NOKOMIS SHORELINE ENHANCEMENT

SHEET 18 OF 35

SEAN JERGENS 10/13/2018 8:05:46 AM H:\PROJECTS\10000\10547\CAD_BIM\PLAN\10547_LAN.DWG: 017
 H:\PROJECTS\10000\10547\CAD_BIM\PLAN\10547_LAN.dwg: 017

PLANT SCHEDULE

QTY.	SIZE	BOTANICAL NAME	COMMON NAME
UPLAND BUFFER DECIDUOUS TREES			
5	2" CAL. B&B	<i>Acer rubrum</i>	Red maple
5	2" CAL. B&B	<i>Quercus bicolor</i>	Swamp white oak
UPLAND BUFFER DECIDUOUS SHRUBS			
10	#2 CONT.	<i>Cornus racemosa</i>	Gray dogwood
10	#2 CONT.	<i>Prunus americana</i>	Wild plum
10	#2 CONT.	<i>Rosa blanda</i>	Pasture rose
10	#2 CONT.	<i>Viburnum lentago</i>	Nannyberry
UPLAND BUFFER HERBACEOUS PERENNIALS			
50	2" PLUG	<i>Asclepias tuberosa</i>	Butterfly milkweed
50	2" PLUG	<i>Coreopsis palmata</i>	Prairie coreopsis
50	2" PLUG	<i>Echinacea angustifolia</i>	Narrow-leaved purple coneflower
50	2" PLUG	<i>Eupatorium perfoliatum</i>	Common boneset
50	2" PLUG	<i>Liatis pycnostachya</i>	Prairie blazing star
50	2" PLUG	<i>Penstemon grandiflorus</i>	Large beardtongue
50	2" PLUG	<i>Symphotrichum laeve</i>	Smooth blue aster
50	2" PLUG	<i>Tradescantia ohimensis</i>	Spiderwort
50	2" PLUG	<i>Verbena hastata</i>	Blue vervain
50	2" PLUG	<i>Zizia aurea</i>	Golden Alexanders

SHORELINE DECIDUOUS TREES			
5	2" CAL. B&B	<i>Populus deltoides</i>	Eastern cottonwood
5	2" CAL. B&B	<i>Salix nigra</i>	Black willow

SHORELINE DECIDUOUS SHRUBS			
15	#2 CONT.	<i>Cornus sericea</i>	Red-osier dogwood
10	#2 CONT.	<i>Cephalanthus occidentalis</i>	Buttonbush

SHORELINE HERBACEOUS PLANTINGS			
25	2" PLUG	<i>Asclepias incarnata</i>	Swamp milkweed
25	2" PLUG	<i>Carex vulpinoidea</i>	Fox sedge
25	2" PLUG	<i>Geranium maculatum</i>	Wild geranium
25	2" PLUG	<i>Hydrophyllum virginianum</i>	Virginia waterleaf
25	2" PLUG	<i>Iris versicolor</i>	Blue flag iris
25	2" PLUG	<i>Juncus torreyi</i>	Torrey's rush
25	2" PLUG	<i>Lobelia siphilitica</i>	Blue lobelia
25	2" PLUG	<i>Pycnanthemum virginianum</i>	Virginia mountain mint
25	2" PLUG	<i>Spartina pectinata</i>	Prairie cordgrass
25	2" PLUG	<i>Zizia aurea</i>	Golden Alexanders

EMERGENT HERBACEOUS PERENNIALS			
100	2" PLUG	<i>Bolboschoenus fluviatilis</i>	River bulrush
100	2" PLUG	<i>Carex lacustris</i>	Lake sedge
8924	2" PLUG	<i>Schoenoplectus acutus</i>	Hard-stem bulrush
100	2" PLUG	<i>Schoenoplectus pungens</i>	Common three-square
100	2" PLUG	<i>Sparganium eurycarpum</i>	Giant bur-reed

- NOTES:
- SEE SPECIFICATIONS FOR ADDITIONAL TREE PROTECTION REQUIREMENTS.
 - TREE PROTECTION FENCE MUST BE MAINTAINED UNTIL COMPLETION OF WORK.
 - NO TREE PRUNING SHALL BE DONE EXCEPT BY MPRB PRUNING PERMIT.
 - NO STORAGE OF MATERIALS OR OPERATION OF EQUIPMENT MAY TAKE PLACE INSIDE TPZ.

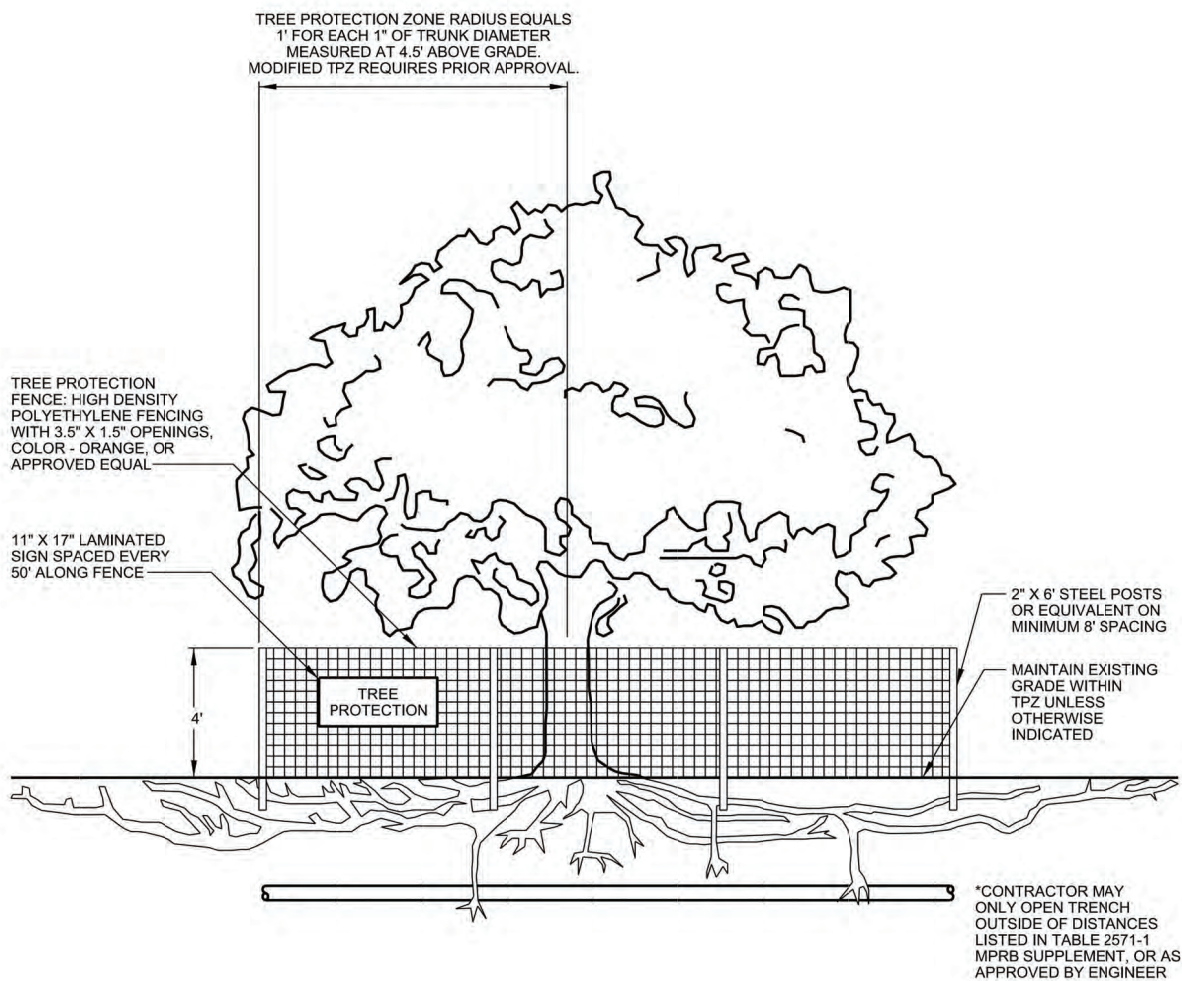

	DRW: CP	DATE: 2/19/16	TREE PROTECTION ZONE (TPZ)	STANDARD PLATE NO. FORE-1001
	APP: RCS	DATE: 2/19/16		

I hereby certify that this plan, specification, or report was prepared by me or under my direct supervision and that I am a duly Licensed Professional Landscape Architect under the laws of the State of Minnesota.

Print Name: SEAN JERGENS

Date: OCTOBER 12, 2018 License # _____

DRAWN BY R. BURAND

DESIGNED BY S. JERGENS

CHECKED BY S. JERGENS

COMM. NO. 10547



MINNEAPOLIS PARK & RECREATION BOARD

LANDSCAPE DETAILS
LAKE NOKOMIS SHORELINE ENHANCEMENT

SHEET

21
OF
35

SEAN_JERGENS.dwg 10/13/2018 7:55:31 AM H:\PROJECTS\10000\10547\CAD_BIM\PLAN\10547_LAN-DTL.DWG: 004
 40 Projects 10000 10547 CAD_BIM\PLAN\10547_LAN-DTL.dwg:004

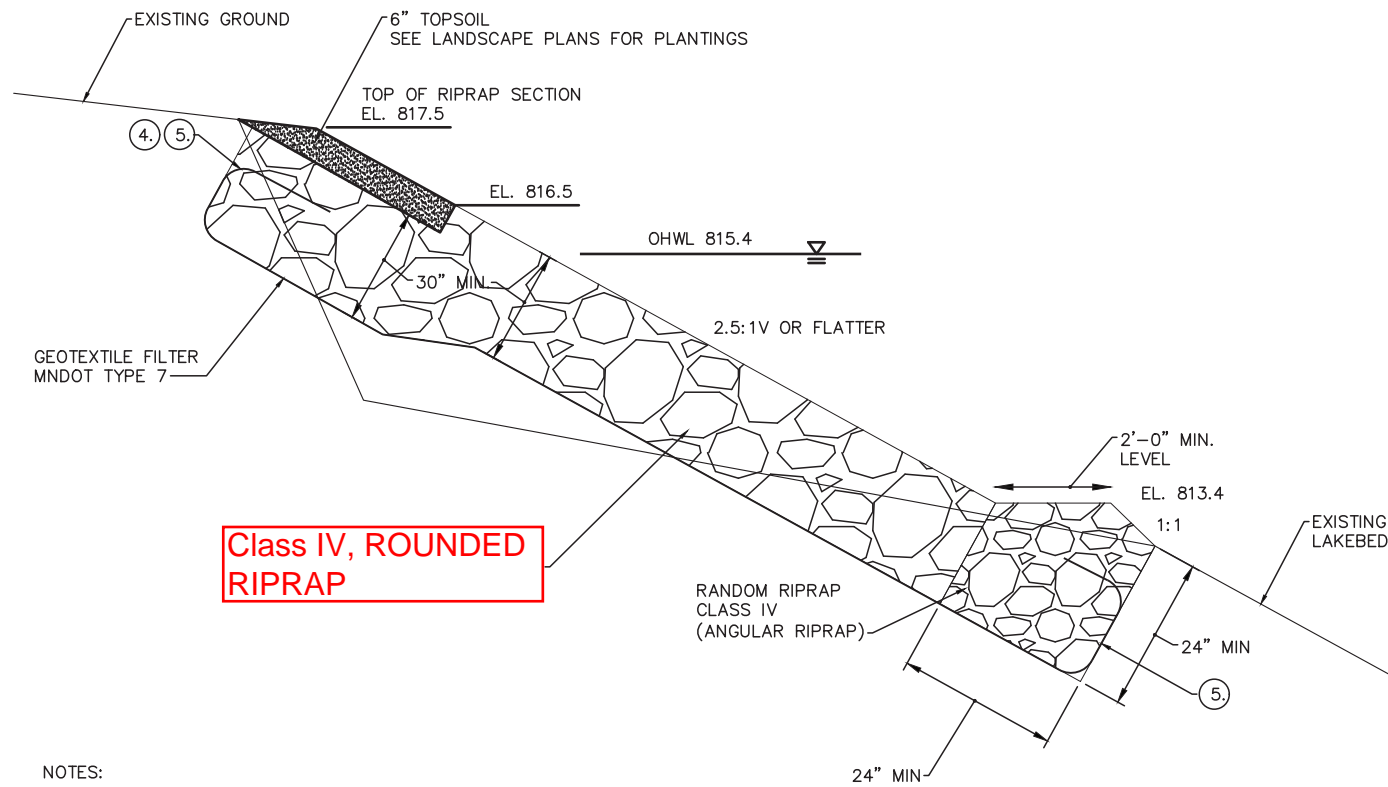

NOTES:

1. GRADE EXISTING GROUND WITH ONSITE MATERIAL FOR PLACEMENT OF THE RIPRAP SLOPE STABILIZATION. TOP OF THE SLOPE SHOULD BE ROUNDED AND SMOOTHED AS SHOWN IN PLAN VIEW. IF LIMESTONE BLOCKS ARE FOUND, THEY SHOULD BE LEFT IN PLACE.
2. RIPRAP PER SPEC. 2511, RANDOM RIPRAP CLASS SPECIAL V BY THE CU. YD. AND RANDOM RIPRAP CLASS IV BY THE CU. YD.
3. PLACE RIPRAP STARTING FROM THE BOTTOM OF THE SLOPE. RANDOM RIPRAP CLASS IV SHALL BE AT LEAST 50% BURIED. DO NOT PLACE RIPRAP SPECIAL (FIELD STONE) UNTIL RIPRAP CLASS IV HAS BEEN PLACED.
4. GEOTEXTILE FILTER TYPE 7 PER SPEC. 3733, BY THE SQ. YD. OVERLAP GEOTEXTILE FILTER 2'-0" MINIMUM.
5. WRAP GEOTEXTILE FILTER AROUND TOE, OVERHANG BETWEEN 1ST AND 2ND LAYER OF RIPRAP. USE HAND PLACEMENT OR SIMILAR METHODS TO ESTABLISH PROFILE AND PLACE FABRIC IF UNDER WATER.
6. BURY EDGES OF GEOTEXTILE FILTER TO DIRECT WATER FLOW OVER THE FABRIC WITHOUT UNDERMINING.

1
22 SHORELINE RIPRAP STABILIZATION TYPE 1 DETAIL
NOT TO SCALE

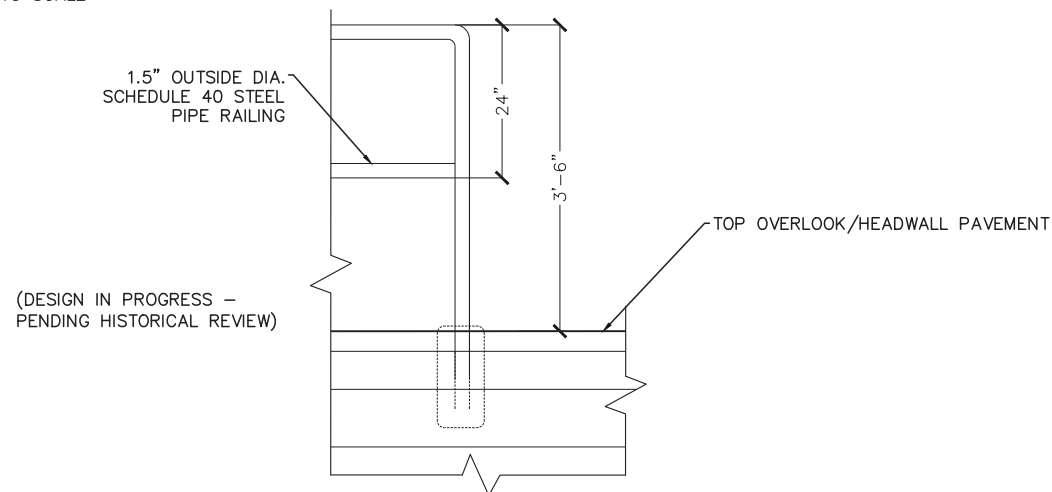

5
22 PEDESTRIAN SAFETY RAILING DETAIL
NOT TO SCALE

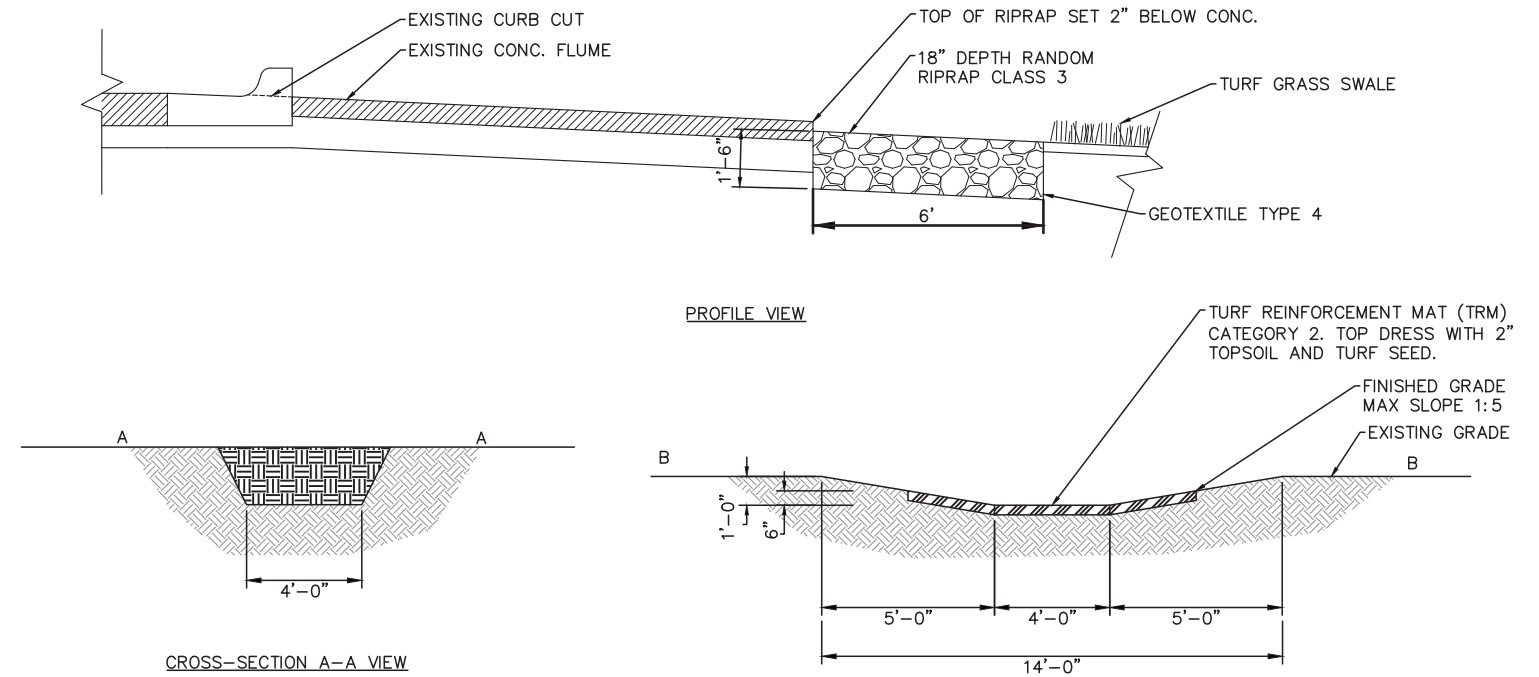

NOTES:

1. REMOVE BROKEN CONC. PAVEMENT FROM ERODING CHANNEL, BELOW INTACT CONC. FLUME.
2. FILL TRENCH WITH EXISTING ON-SITE TOPSOIL AND RE-GRADE ADJACENT SLOPE. FINISHED GRADE SHALL NOT EXCEED 1:6.
3. INSTALL TRM CATEGORY 2 PER MNDOT STANDARD SPECIFICATION 3885. FOLLOW MANUFACTURER'S RECOMMENDATION FOR PERMANENT ANCHORING AND PLACEMENT.

2
22 CHANNEL EROSION REPAIR DETAIL
NOT TO SCALE

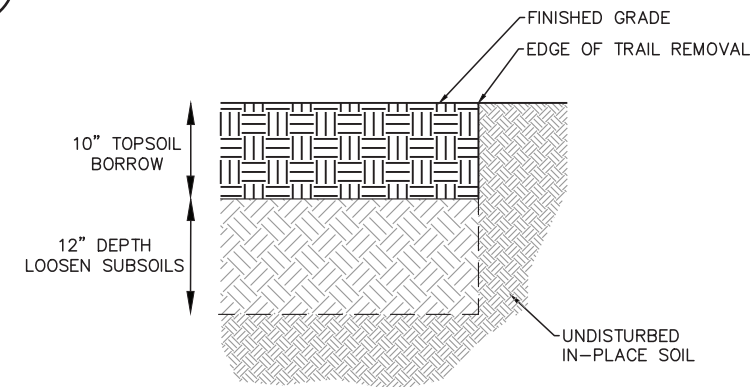

NOTES:

1. REMOVE EXISTING ASPHALT TRAIL AND COMPACTED AGGREGATE BASE.
2. LOOSEN SUBSOILS TO DEPTH OF 12" WITH FROST RIPPER.
3. PLACE TOPSOIL BORROW AND MATCH EXISTING GRADE AT EDGES.
4. SEE LANDSCAPE PLANS FOR NATIVE SEEDING.

3
22 TRAIL REMOVAL AND SOIL REPAIR DETAIL
NOT TO SCALE

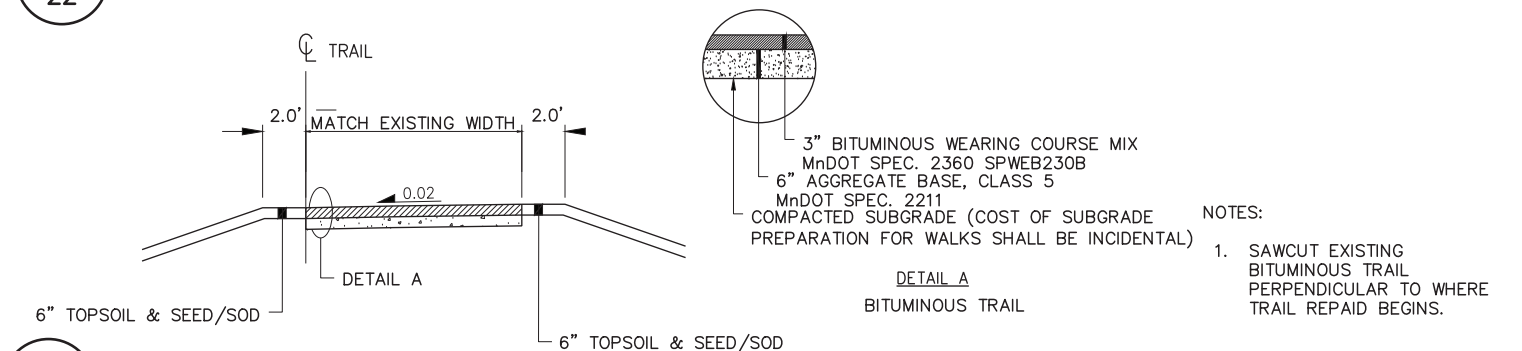

4
22 BITUMINOUS TRAIL REPAIR DETAIL
NOT TO SCALE

SEAN JERGENS 10/13/2018 7:55:31 AM H:\PROJECTS\10000\10547\CAD_BIM\PLAN\10547_LAN-DTL.dwg

NO	DATE	BY	CHKD	APPR

I hereby certify that this plan, specification, or report was prepared by me or under my direct supervision and that I am a duly Licensed Professional Landscape Architect under the laws of the State of Minnesota.
Print Name: SEAN JERGENS
Date: OCTOBER 12, 2018 License # _____

DRAWN BY: R. BURAND
DESIGNED BY: S. JERGENS
CHECKED BY: S. JERGENS
CITY PROJECT NO. ## COMM. NO. 10547



MINNEAPOLIS PARK & RECREATION BOARD
LANDSCAPE DETAILS
LAKE NOKOMIS SHORELINE ENHANCEMENT

SHEET
22
OF
35

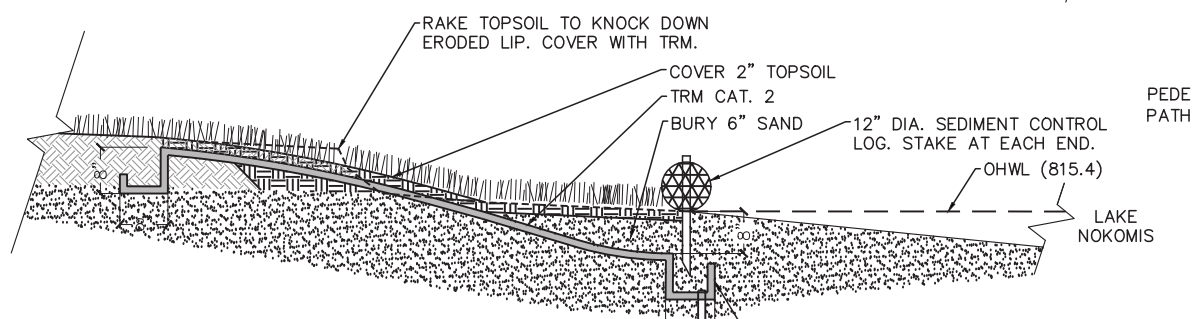
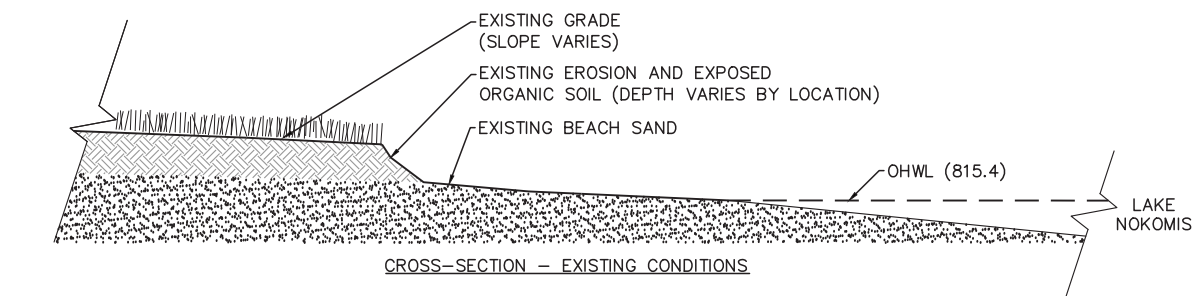

- NOTES:
1. KNOCK DOWN ERODED ORGANIC SOIL RIDGE AND SMOOTH INTO FINISHED GRADE. APPLY TURF REINFORCEMENT MAT (TRM).
 2. FILL TRM WITH 2" TOPSOIL ON PEDESTRIAN ACCESS PATH. COVER WITH 1" TOPSOIL AND 6" SAND IN EXISTING BEACH SAND AREAS. APPLY TURF SEED TO PEDESTRIAN PATH AS SHOWN IN THE LANDSCAPE PLANS.
 3. NO GRADING PERMITTED OUTSIDE OF THE CONSTRUCTION LIMITS. NO FILL PERMITTED AT OR BELOW WETLAND BOUNDARY OR OHWL.

1
23 SHORELINE ACCESS SITE EROSION REPAIR DETAIL
NOT TO SCALE

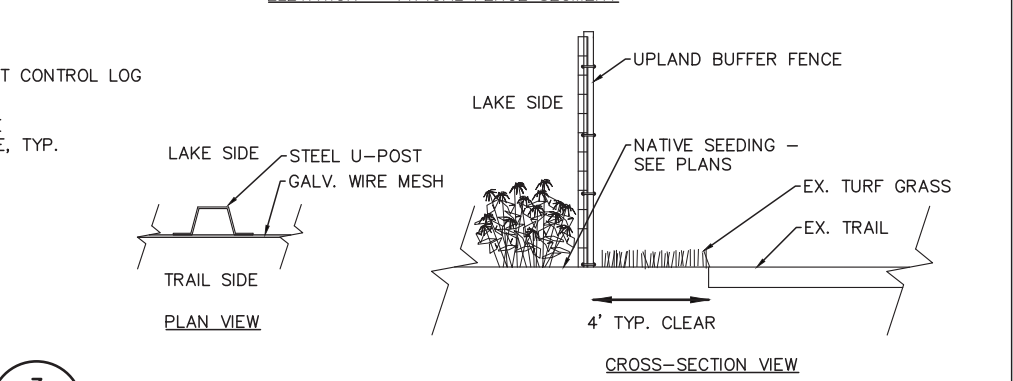
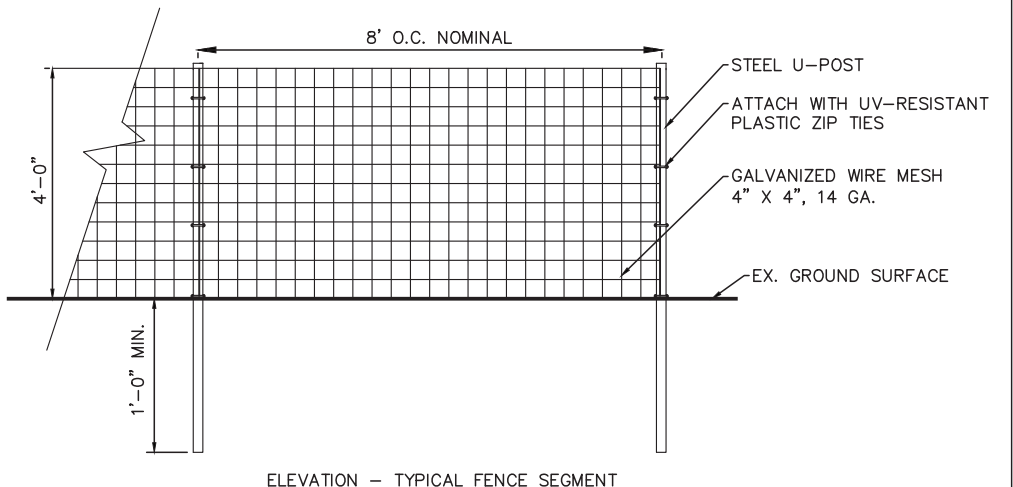
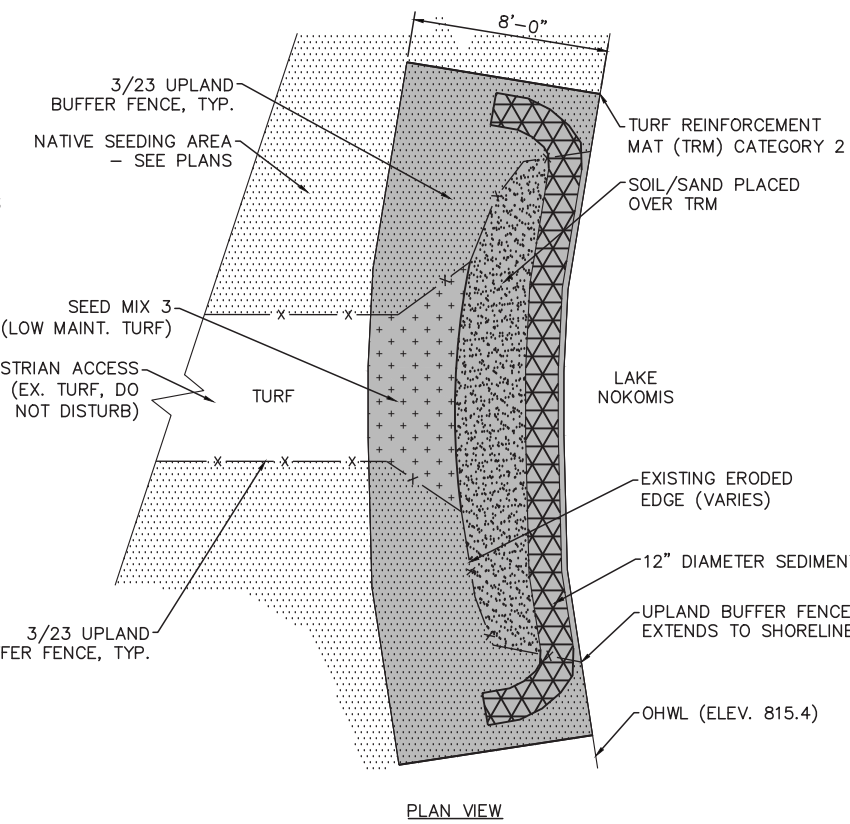

3
23 UPLAND BUFFER FENCE DETAIL
NOT TO SCALE

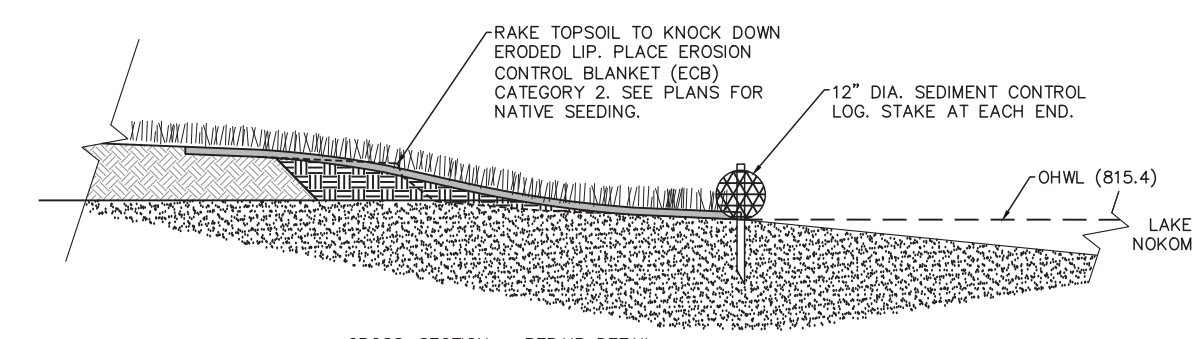
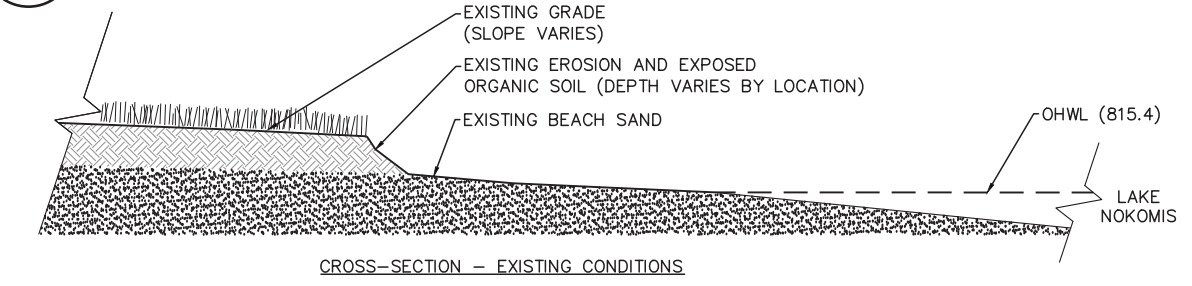

- NOTES:
1. KNOCK DOWN ERODED ORGANIC SOIL RIDGE AND SMOOTH INTO FINISHED GRADE. APPLY TURF REINFORCEMENT MAT (TRM).
 2. PLACE EROSION CONTROL BLANKET. APPLY NATIVE SEED TO SHORELINE AND UPLAND ZONES AS SHOWN IN THE LANDSCAPE PLANS.
 3. NO GRADING PERMITTED OUTSIDE OF THE CONSTRUCTION LIMITS. NO FILL PERMITTED AT OR BELOW WETLAND BOUNDARY OR OHWL.

2
23 SHORELINE REVEGETATION SITE EROSION REPAIR DETAIL
NOT TO SCALE

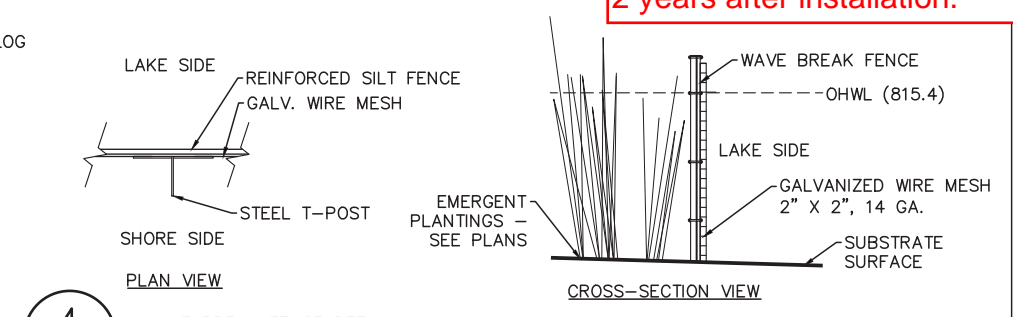
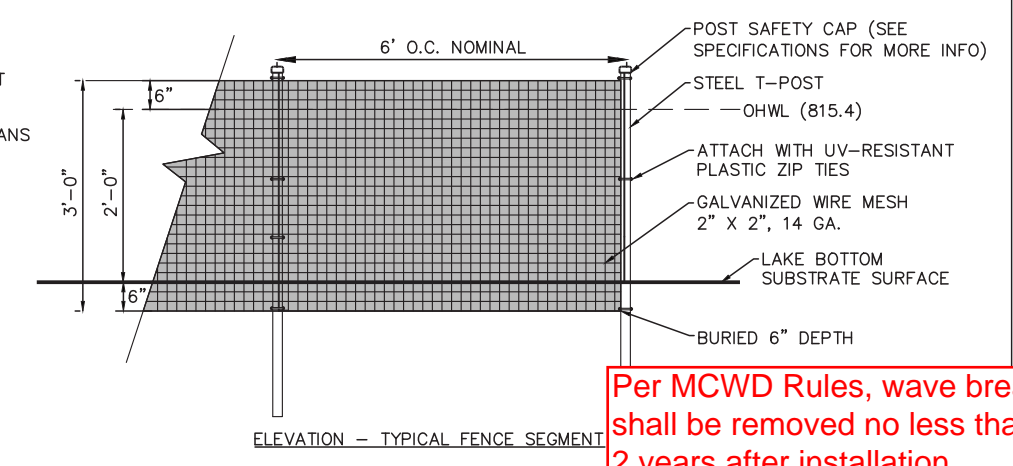
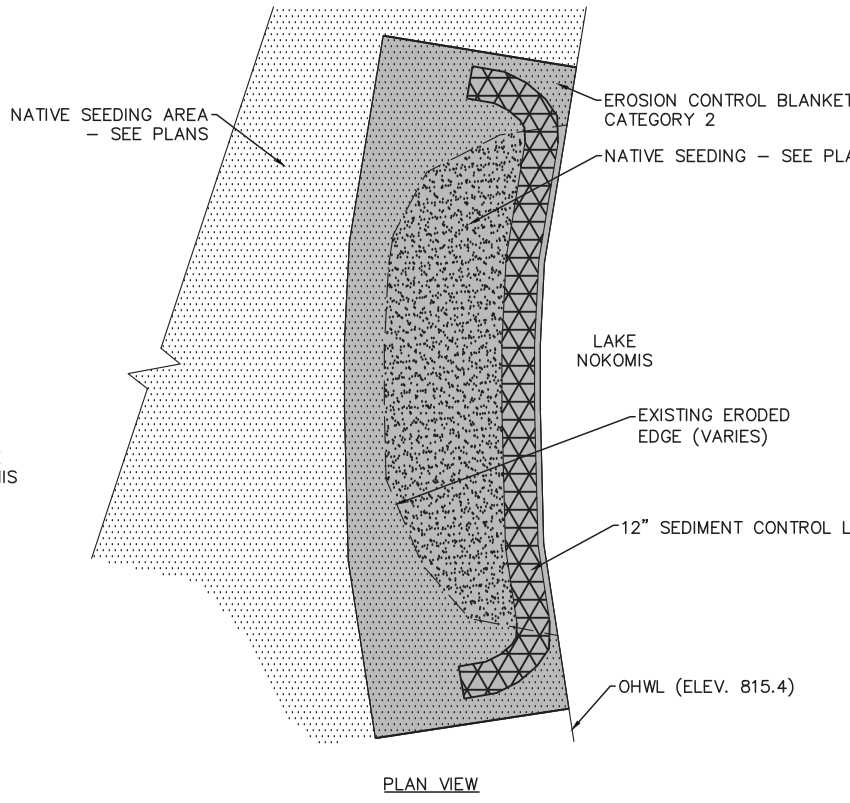

4
23 WAVE BREAK FENCE DETAIL
NOT TO SCALE

Per MCWD Rules, wave break shall be removed no less than 2 years after installation.

SEAN JERGENS 10/13/2018 7:55:31 AM H:\PROJECTS\10000\10547\CAD_BIM\PLAN\10547_LAN-DTL.dwg:006

NO	DATE	BY	CHKD	APPR

I hereby certify that this plan, specification, or report was prepared by me or under my direct supervision and that I am a duly Licensed Professional Landscape Architect under the laws of the State of Minnesota.
Print Name: SEAN JERGENS
Date: OCTOBER 12, 2018 License # _____ CITY PROJECT NO. ##

DRAWN BY: R. BURAND
DESIGNED BY: S. JERGENS
CHECKED BY: S. JERGENS
COMM. NO. 10547

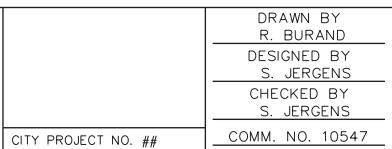

MINNEAPOLIS PARK & RECREATION BOARD
LANDSCAPE DETAILS
LAKE NOKOMIS SHORELINE ENHANCEMENT

SHEET 23 OF 35

SEAN JERGENS | 10/10/2018 1:20:27 AM
 21.05 (LMS TECH) | C:\Users\sjergens\AppData\Roaming\Autodesk\C3D 2017\enu\H:\Projects\10000\10547\CAD_BIM\Plan\10547_REM.dwg-REM-01

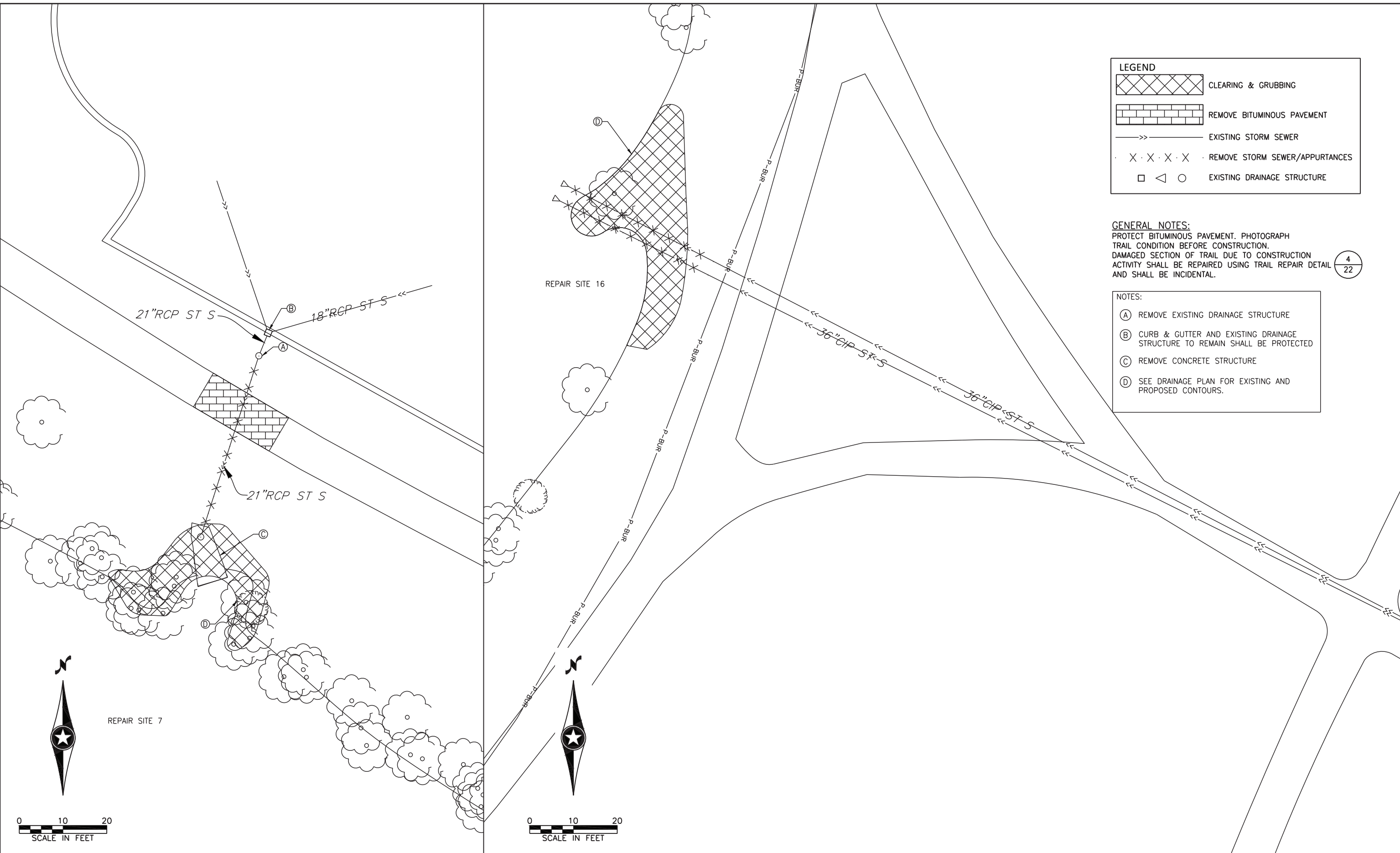

LEGEND

- CLEARING & GRUBBING
- REMOVE BITUMINOUS PAVEMENT
- EXISTING STORM SEWER
- REMOVE STORM SEWER/APPURTANCES
- EXISTING DRAINAGE STRUCTURE

GENERAL NOTES:
 PROTECT BITUMINOUS PAVEMENT. PHOTOGRAPH TRAIL CONDITION BEFORE CONSTRUCTION. DAMAGED SECTION OF TRAIL DUE TO CONSTRUCTION ACTIVITY SHALL BE REPAIRED USING TRAIL REPAIR DETAIL AND SHALL BE INCIDENTAL.

- NOTES:**
- (A) REMOVE EXISTING DRAINAGE STRUCTURE
 - (B) CURB & GUTTER AND EXISTING DRAINAGE STRUCTURE TO REMAIN SHALL BE PROTECTED
 - (C) REMOVE CONCRETE STRUCTURE
 - (D) SEE DRAINAGE PLAN FOR EXISTING AND PROPOSED CONTOURS.

4
22

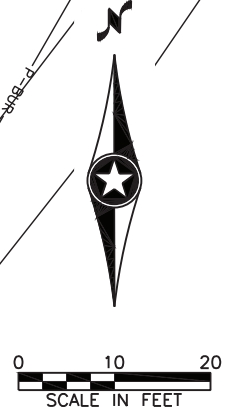
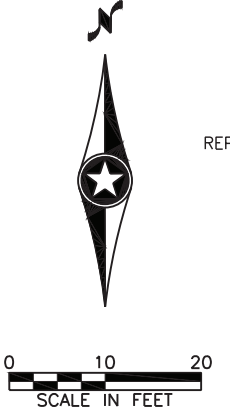

NO	DATE	BY	CKD	APPR

I hereby certify that this plan, specification, or report was prepared by me or under my direct supervision and that I am a duly Licensed Professional Engineer under the laws of the State of Minnesota.
 Print Name: LEAH GIFFORD
 Date _____ License # LIC # 5

STATE AID PROJECT NO. _____
 S(A)P _____
 S(A)P _____
 S(A)P _____
 STATE PROJECT NO. _____
 COUNTY PROJECT NO. _____
 CITY PROJECT NO. ## _____

DRAWN BY
J. SWANSON
 DESIGNED BY
L. GIFFORD
 CHECKED BY
CHECKED 10
 COMM. NO. 10547



MINNEAPOLIS PARK & RECREATION BOARD
 DRAINAGE REMOVALS
 LAKE NOKOMIS SHORELINE ENHANCEMENT

SHEET
24
 OF
 35

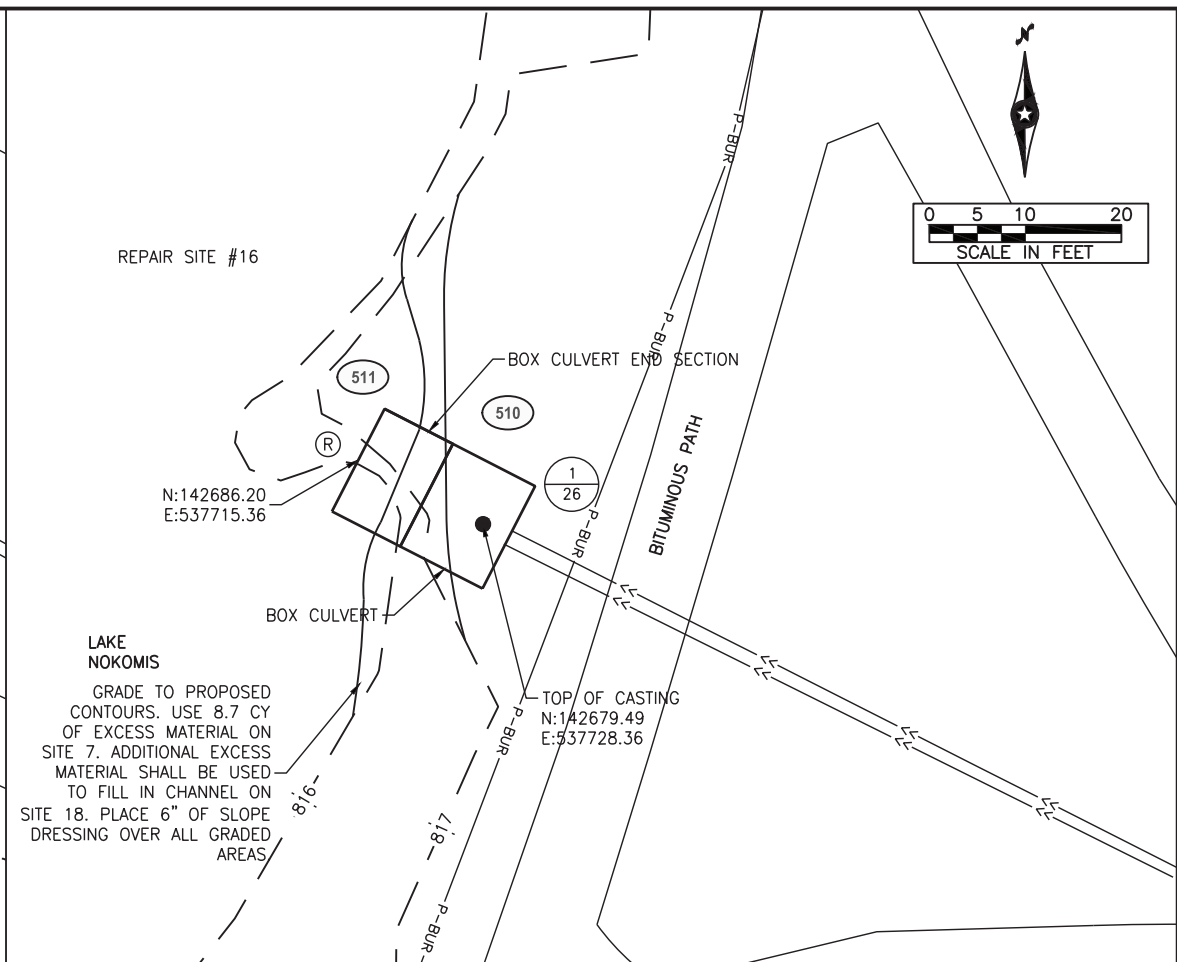
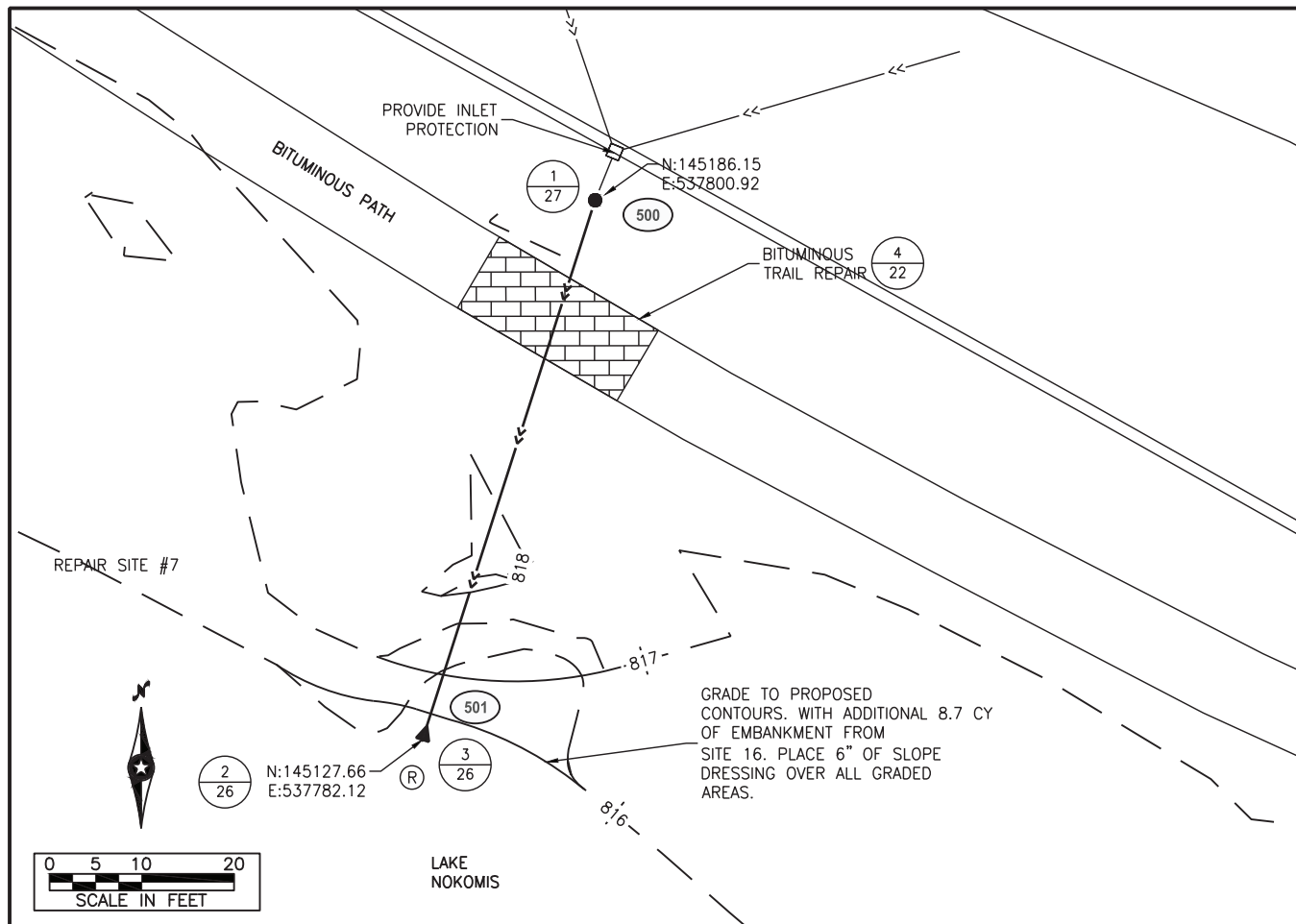

LEGEND

- EXISTING CONTOUR
- - - PROPOSED CONTOUR
- >> EXISTING STORM SEWER
- >> PROPOSED STORM SEWER
- PROPOSED MANHOLE
- ▲ PROPOSED APRON
- PROPOSED STORM SEWER
- Ⓡ RIPRAP

NOTES:

FIELD LOCATE UTILITIES.

SEE SHEETS 26 - 32 FOR DETAIL AND STANDARD PLATES.

INVERT ELEVATIONS ARE GIVEN TO EDGE OF STRUCTURE OR END OF APRON.

TOP OF CASTING ELEVATIONS ARE CENTER OF CASTING ASSEMBLY.

APRON LENGTH INCLUDED IN LENGTH OF PIPE.

ALL RC PIPES ARE CL II UNLESS NOTED.

TIE LAST THREE PIPE JOINTS TO APRON END.

NOTES:

① SOIL AROUND CASTING SHALL BE GRADED TO MATCH TOP OF CASTING ELEVATION.

② CASTING ASSEMBLY SHALL BE CENTERED 3FT FROM THE EASTERN EDGE OF THE BOX CULVERT.

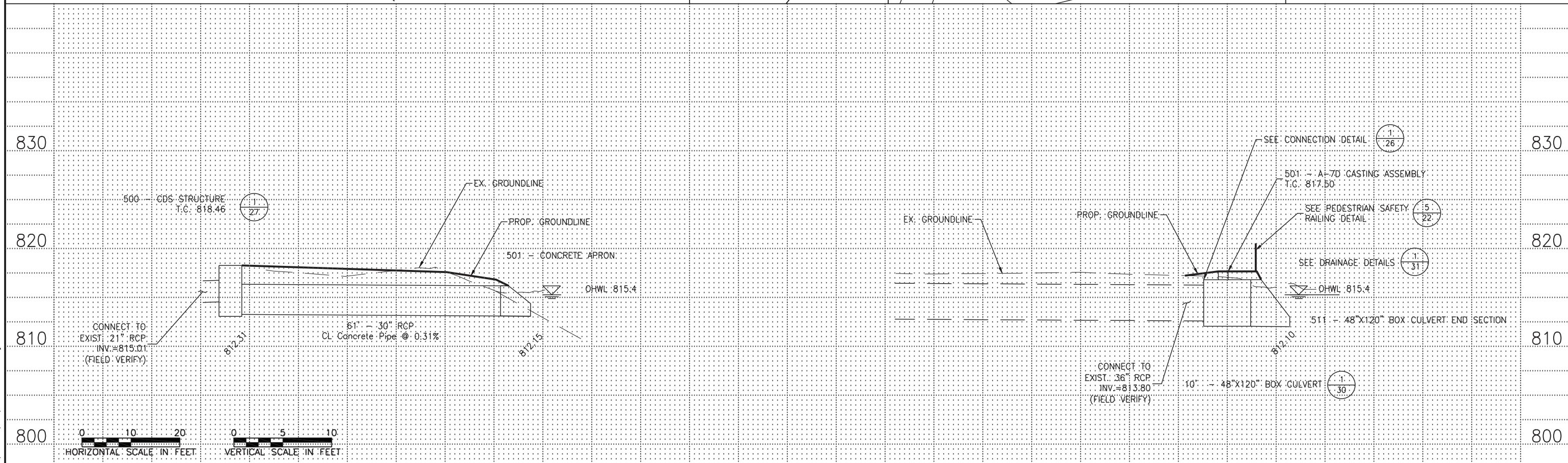

SCAN: JERGENS | 10/8/2018 4:20:03 PM
 2105 (LMS TECH) | C:\Users\jg\AppData\Local\Temp\AutoDesk\C3D 2017\enu\...
 H:\PROJECTS\10000\10547\CAD_BIM\PLAN\10547_STM-PLN.dwg:001

NO	DATE	BY	CHKD	APPR

I hereby certify that this plan, specification, or report was prepared by me or under my direct supervision and that I am a duly Licensed Professional Engineer under the laws of the State of Minnesota.
 Print Name: **LEAH GIFFORD**
 Date: **6/1/2018** License #: **#####**

DRAWN BY
M. MCGINN
 DESIGNED BY
M. MCGINN
 CHECKED BY
L. GIFFORD
 COMM. NO. **10547**



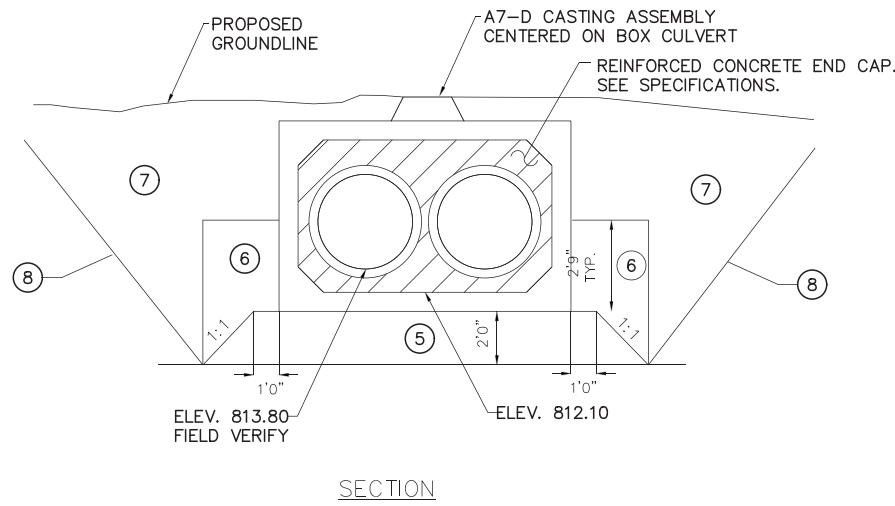

DESIGN DATA	
2017 AND CURRENT INTERIM AASHTO LRFD BRIDGE DESIGN SPECIFICATIONS	
LOAD AND RESISTANCE FACTOR DESIGN METHOD	
HL 93 LIVE LOAD	
INSIDE HEIGHT =	4'0"
INSIDE WIDTH =	10'0"
DEPTH OF DROPWALL =	3'2"
HEIGHT OF WINGWALL AT END =	2'0"
SKEW ANGLE =	00°-00'-00"
MINIMUM DESIGN FILL DEPTH =	<3'-0"
MAXIMUM DESIGN FILL DEPTH =	<3'-0"
UNIT WEIGHT FILL =	120.0 LBS./CU. FT.
ANGLE INTERNAL FRICTION =	30°
f_y =	60000 P.S.I. REINFORCEMENT BARS
f_y =	65000 P.S.I. STEEL FABRIC
f'_c =	5000 P.S.I. CONCRETE

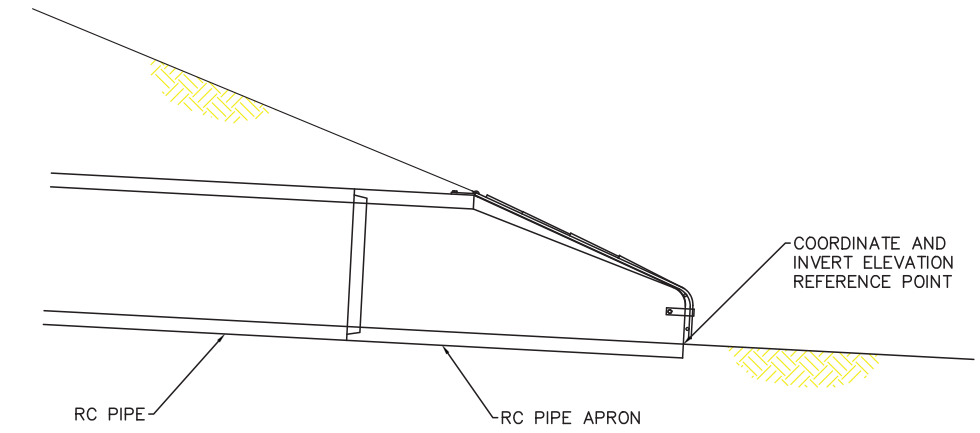
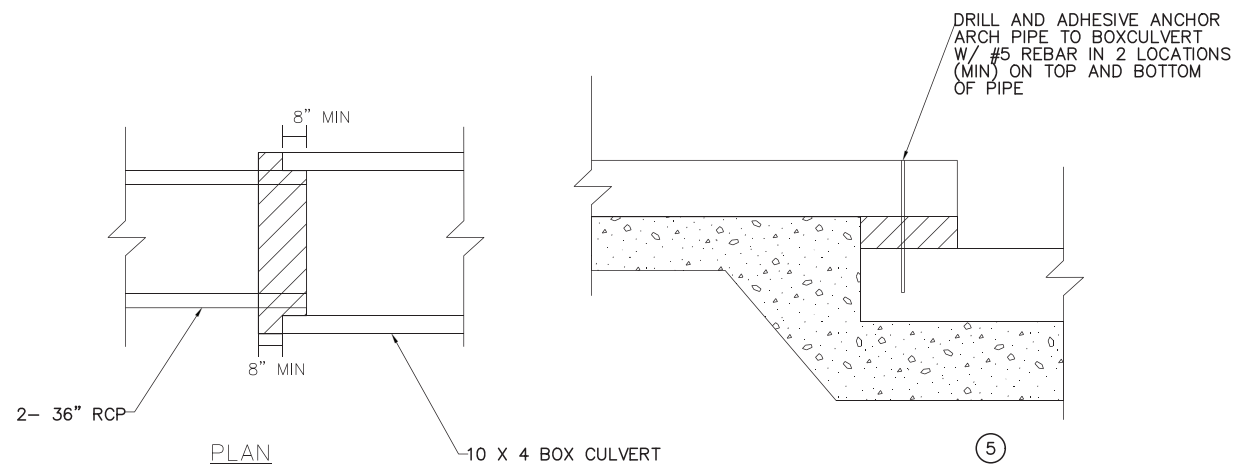

2
26 STAKING DETAIL PIPE APRONS
NOT TO SCALE

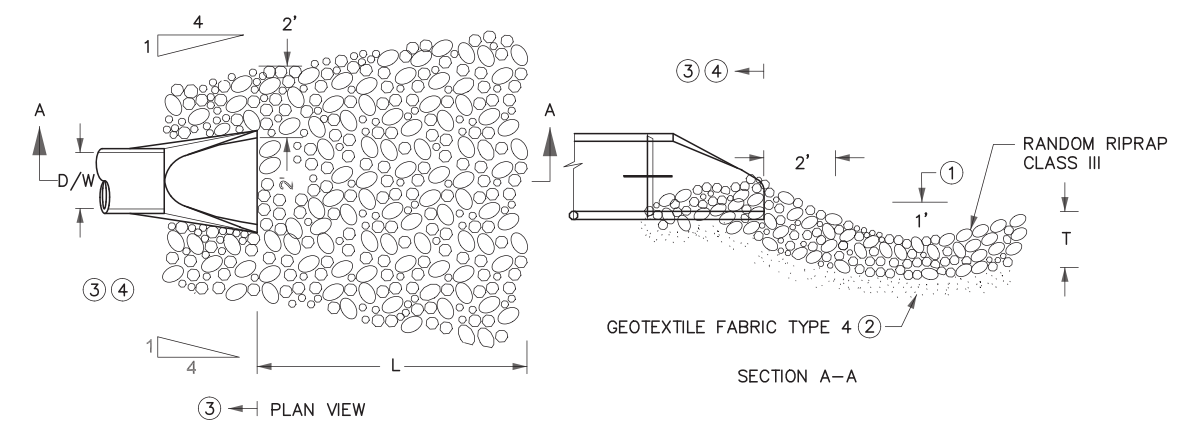

SITE	D/W	L	T
REPAIR SITE 7	30"	14'	18"
REPAIR SITE 16	10'	20'	18"
REPAIR SITE 18	UNKNOWN	8'	18"

- NOTES:
- FOR PIPES GREATER THAN OR EQUAL TO 30" USE 1.5'.
 - GEOTEXTILE FABRIC TYPE 4. FABRIC SHALL COVER THE AREA OF RIPRAP AND EXTEND UNDER THE CULVERT APRON 3 FT. FABRIC SHALL MEET MNDOT SPEC. 3733.
 - BURY THE RIPRAP PLACED BESIDE AND ABOVE THE APRON INVERT ELEVATION. 6" OF TOPSOIL, EROSION CONTROL BLANKET TYPE 4, AND SEED SHALL BE PLACED ON TOP OF RIPRAP AND SHALL MATCH THE SHORELINE SLOPE BESIDE IT. (SEE LANDSCAPE PLAN)
 - SEE MNDOT STANDARD PLATE FOR EMBANKMENT PROTECTION FOR BOX CULVERTS.

3
26 RIPRAP AT OUTLETS (MODIFIED FROM MINNEAPOLIS STANDARD PLATE SEWER-3005)
NOT TO SCALE

1
26 RCP PIPE AND BOX CULVERT CONNECTION DETAIL
NOT TO SCALE

- NOTES:
- SEE STORM SEWER PROFILES.
 - SEE STANDARD BOX CULVERT AND END SECTION PLANS.
 - SEE STANDARD PLANS FOR EMBANKMENT PROTECTION.
 - ALL RIPRAP SHALL BE CLASS III.
 - AGGREGATE BEDDING PER SPEC. 3149.2G COMPACT TO A MINIMUM SPECIFIED DENSITY OF 98%.
 - SELECT GRANULAR BORROW PER SPEC 3149.2B2. COMPACT PER SPEC 2106.3F1
 - ONSITE GRADING MATERIAL.
 - APPROXIMATE LIMIT FOR STRUCTURAL EXCAVATION. ACTUAL EXCAVATION SLOPE IS DETERMINED BY OSHA REGULATIONS AND INSITU SOILS.
 - PER SPEC 2412.5, THE CONTRACT UNIT PRICE FOR PRECAST CONCRETE BOX CULVERT AND END SECTIONS WILL INCLUDE THE COST OF PROVIDING AND INSTALLING CULVERTS, END SECTIONS, TRANSITIONS, EXCAVATION, FOUNDATION PREPARATION, BEDDING MATERIAL AND BACKFILL MATERIALS.

SEAN JERGENS 10/10/2018 1:20:40 AM
 H:\PROJECTS\10000\10547\CAD_BIM\PLAN\10547_STM-DTL.DWG: 001

NO	DATE	BY	CHKD	APPR

I hereby certify that this plan, specification, or report was prepared by me or under my direct supervision and that I am a duly Licensed Professional Engineer under the laws of the State of Minnesota.
 Print Name: LEAH GIFFORD
 Date: OCTOBER 12, 2018 License # #####

DRAWN BY
J. SWANSON
 DESIGNED BY
L. GIFFORD
 CHECKED BY
S. JERGENS
 COMM. NO. 10547



MINNEAPOLIS PARK & RECREATION BOARD
 DRAINAGE DETAILS
 LAKE NOKOMIS SHORELINE ENHANCEMENT

SHEET
26
OF
35

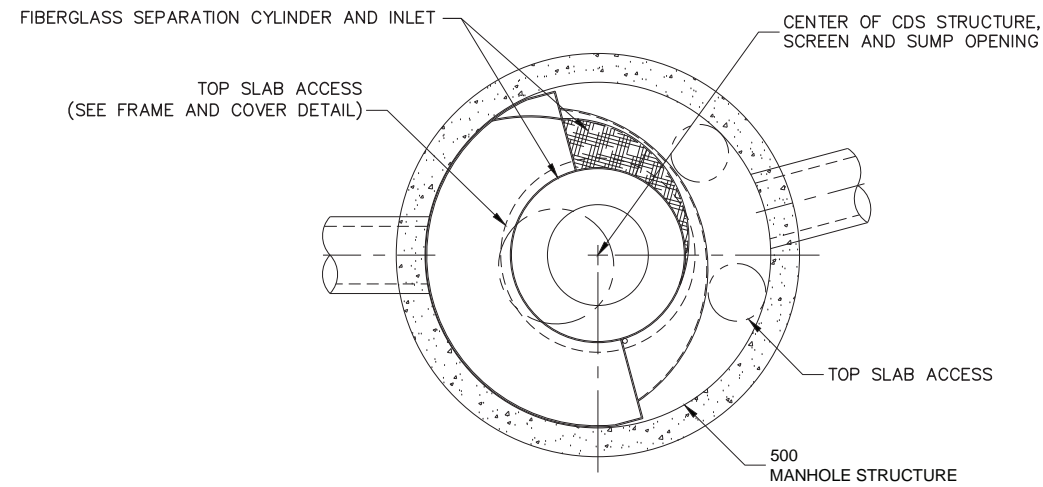

CDS3020-6-C DETAIL NOTES

RATED TREATMENT CAPACITY IS 2.0 CFS [56.6 L/s], OR PER LOCAL REGULATIONS. MAXIMUM HYDRAULIC INTERNAL BYPASS CAPACITY IS 20.0 CFS [566 L/s]. IF THE SITE CONDITIONS EXCEED 20.0 CFS [566 L/s], AN UPSTREAM BYPASS STRUCTURE IS REQUIRED.

THE STANDARD ##### CONFIGURATION IS SHOWN. ALTERNATE CONFIGURATIONS ARE AVAILABLE AND ARE LISTED BELOW. SOME CONFIGURATIONS MAY BE COMBINED TO SUIT SITE REQUIREMENTS.

CONFIGURATION DESCRIPTION

- GRATED INLET ONLY (NO INLET PIPE)
- GRATED INLET WITH INLET PIPE OR PIPES
- CURB INLET ONLY (NO INLET PIPE)
- SEPARATE OIL BAFFLE (SINGLE INLET PIPE REQUIRED FOR THIS CONFIGURATION)
- CURB INLET WITH INLET PIPE OR PIPES
- SEDIMENT WEIR FOR NJDEP / NJCAT CONFORMING UNITS

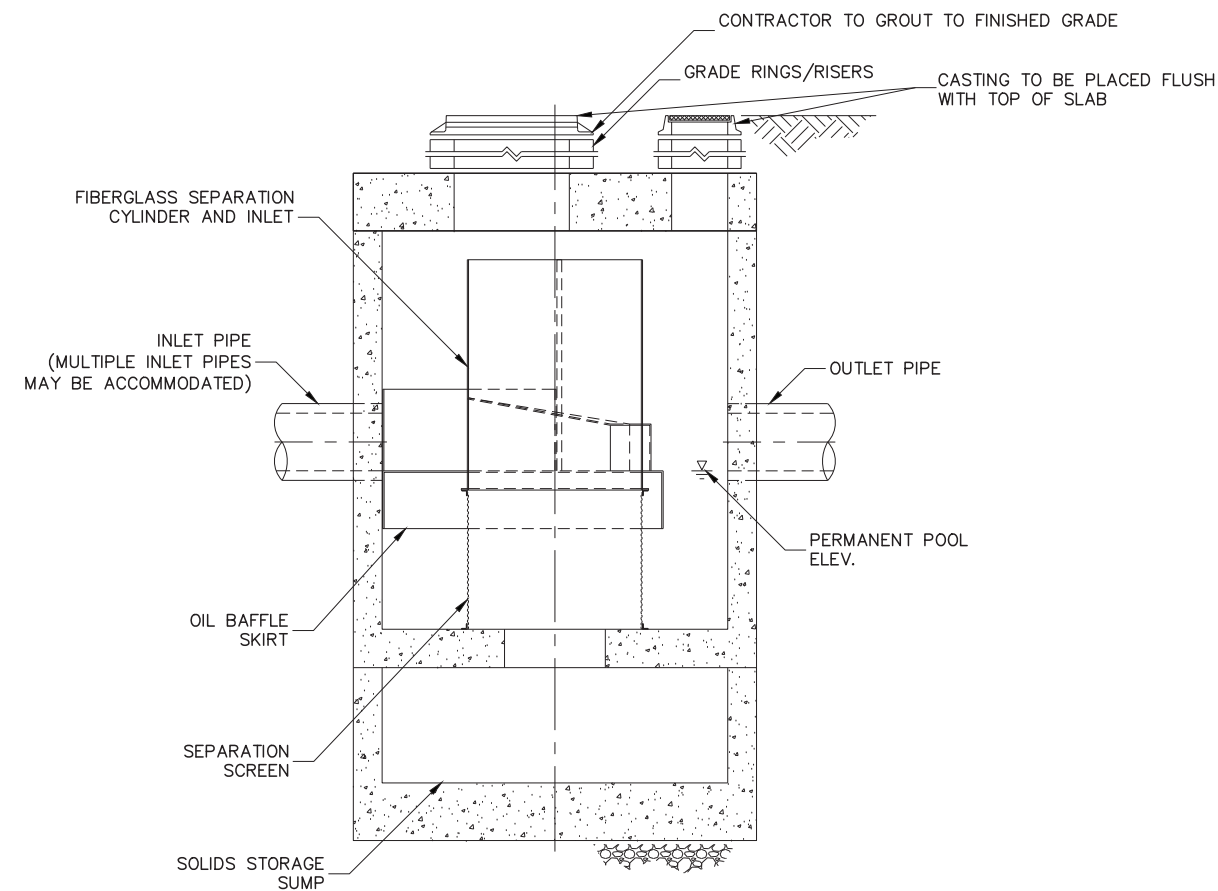

SITE SPECIFIC DATA REQUIREMENTS

STRUCTURE ID	500		
WATER QUALITY FLOW RATE (CFS OR L/s)	13.3		
PEAK FLOW RATE (CFS OR L/s)	15.9		
RETURN PERIOD OF PEAK FLOW (YRS)	100		
SCREEN APERTURE (2400 OR 4700)	MICRON		
PIPE DATA:	I.E.	MATERIAL	DIAMETER
INLET PIPE 1	815.01	RCP	21"
OUTLET PIPE	812.31	RCP	30"
RIM ELEVATION	818.46		
ANTI-FLOTATION BALLAST	WIDTH	HEIGHT	
NOTES/SPECIAL REQUIREMENTS:			
* PER ENGINEER OF RECORD			

GENERAL NOTES

1. CONTECH TO PROVIDE ALL MATERIALS UNLESS NOTED OTHERWISE.
2. FOR SITE SPECIFIC DRAWINGS WITH DETAILED STRUCTURE DIMENSIONS AND WEIGHT, PLEASE CONTACT YOUR CONTECH ENGINEERED SOLUTIONS LLC REPRESENTATIVE. www.ContechES.com
3. CDS WATER QUALITY STRUCTURE SHALL BE IN ACCORDANCE WITH ALL DESIGN DATA AND INFORMATION CONTAINED IN THIS DRAWING. CONTRACTOR TO CONFIRM STRUCTURE MEETS REQUIREMENTS OF PROJECT.
4. STRUCTURE SHALL MEET AASHTO HS20 LOAD RATING, ASSUMING EARTH COVER OF 0' - 2', AND GROUNDWATER ELEVATION AT, OR BELOW, THE OUTLET PIPE INVERT ELEVATION. ENGINEER OF RECORD TO CONFIRM ACTUAL GROUNDWATER ELEVATION. CASTINGS SHALL MEET AASHTO M306 AND BE CAST WITH THE CONTECH LOGO..
5. IF REQUIRED, PVC HYDRAULIC SHEAR PLATE IS PLACED ON SHELF AT BOTTOM OF SCREEN CYLINDER. REMOVE AND REPLACE AS NECESSARY DURING MAINTENANCE CLEANING.
6. CDS STRUCTURE SHALL BE PRECAST CONCRETE CONFORMING TO ASTM C-478 AND AASHTO LOAD FACTOR DESIGN METHOD.

INSTALLATION NOTES

- A. ANY SUB-BASE, BACKFILL DEPTH, AND/OR ANTI-FLOTATION PROVISIONS ARE SITE-SPECIFIC DESIGN CONSIDERATIONS AND SHALL BE SPECIFIED BY ENGINEER OF RECORD.
- B. CONTRACTOR TO PROVIDE EQUIPMENT WITH SUFFICIENT LIFTING AND REACH CAPACITY TO LIFT AND SET THE CDS MANHOLE STRUCTURE.
- C. CONTRACTOR TO INSTALL JOINT SEALANT BETWEEN ALL STRUCTURE SECTIONS AND ASSEMBLE STRUCTURE.
- D. CONTRACTOR TO PROVIDE, INSTALL, AND GROUT INLET AND OUTLET PIPE(S). MATCH PIPE INVERTS WITH ELEVATIONS SHOWN. ALL PIPE CENTERLINES TO MATCH PIPE OPENING CENTERLINES.
- E. CONTRACTOR TO TAKE APPROPRIATE MEASURES TO ASSURE UNIT IS WATER TIGHT, HOLDING WATER TO FLOWLINE INVERT MINIMUM. IT IS SUGGESTED THAT ALL JOINTS BELOW PIPE INVERTS ARE GROUTED.

1
27 CDS STRUCTURE
NOT TO SCALE

I hereby certify that this plan, specification, or report was prepared by me or under my direct supervision and that I am a duly Licensed Professional Engineer under the laws of the State of Minnesota.

Print Name: LEAH GIFFORD

Date OCTOBER 12, 2018 License # #####

DRAWN BY
J. SWANSON
DESIGNED BY
L. GIFFORD
CHECKED BY
S. JERGENS

COMM. NO. 10547



MINNEAPOLIS PARK & RECREATION BOARD
DRAINAGE DETAILS
LAKE NOKOMIS SHORELINE ENHANCEMENT

SHEET
27
OF
35

SEAN JERGENS 10/10/2018 1:20:40 AM
 H:\PROJECTS\10000\10547\CAD_BIM\PLAN\10547_STM-DTL.DWG: 002

NO DATE BY CKD APPR
H:\PROJECTS\10000\10547\CAD_BIM\PLAN\10547_STM-DTL.DWG: 002

STORM WATER POLLUTION PREVENTION PLAN (SWPPP) NARRATIVE (SHEET 1 OF 3)

PROJECT DESCRIPTION/LOCATION AND SCOPE

SEE COVER SHEET FOR LOCATION MAP, PROJECT NUMBERS AND DESCRIPTION OF PROJECT SCOPE.

PERMANENT STORMWATER BEST MANAGEMENT PRACTICES (BMPs) UTILIZED ON THE PROJECT INCLUDE RIPRAP BELOW THE ORDINARY HIGH WATER LEVEL AT RECONSTRUCTED OUTLETS. TEMPORARY BMPs UTILIZED ON THE PROJECT INCLUDE, BUT ARE NOT LIMITED TO, FLOATATION SILT CURTAIN, PERIMETER CONTROL FOR WORK ON THE SHORELINE AND BELOW THE WATERLINE AND CHIP SACK ROLLS FOR WORK THAT IS TO OCCUR AT OR ABOVE THE ORDINARY HIGH WATER LEVEL.

SPECIAL AND IMPAIRED WATERS

THE FOLLOWING SPECIAL/IMPAIRED WATERS ARE LOCATED WITHIN ONE MILE OF THE PROJECT LIMITS AND RECEIVE RUNOFF FROM THE PROJECT SITE.

LAKE NOKOMIS IS IMPAIRED FOR NUTRIENTS, AQUATIC CONSUMPTION, AND AQUATIC RECREATION AND IS A DESIGNATED INFESTED WATER LISTED FOR EUASIAN WATER MILFOIL AND ZEBRA MUSSELS.

MINNEHAHA CREEK IS IMPAIRED FOR CHLORIDES, DISSOLVED OXYGEN, FECAL COLIFORM, AQUATIC LIFE, AND AQUATIC RECREATION.

LAKE HIAWATHA IS IMPAIRED FOR AQUATIC RECREATION.

ENVIRONMENTALLY SENSITIVE AREAS

ALL ENVIRONMENTALLY SENSITIVE AREAS, INCLUDING WETLANDS, ARE LABELED AS "DELINEATED WETLAND BOUNDARY" IN THE PLANS.

LONG TERM MAINTENANCE AND OPERATION

MAINTENANCE STAFF FROM THE CITY OF MINNEAPOLIS ARE RESPONSIBLE FOR THE LONG TERM MAINTENANCE AND OPERATION OF THE PERMANENT STORMWATER SYSTEMS.

SWPPP DEVELOPMENT AND MAINTENANCE

THIS SWPPP WAS PREPARED BY PERSONNEL WHO ARE CERTIFIED IN THE DESIGN OF CONSTRUCTION SWPPPS. COPIES OF THE CERTIFICATIONS ARE AVAILABLE UPON REQUEST.

THE CONTRACTOR SHALL BE RESPONSIBLE FOR PROVIDING A CERTIFIED EROSION AND SEDIMENT CONTROL SUPERVISOR WHO SHALL BE RESPONSIBLE FOR FINALIZING, CERTIFYING, AND MAINTAINING THE SWPPP DOCUMENT AND OVERSEEING THE IMPLEMENTATION OF THE SWPPP. SEE PAGE 2 OF THE SWPPP NARRATIVE FOR ADDITIONAL REQUIREMENTS.

SWPPP AMENDMENTS

THE SWPPP SHALL BE AMENDED WHEN:

- A. THERE IS A CHANGE IN DESIGN, CONSTRUCTION, OPERATION, MAINTENANCE, WEATHER OR SEASON HAVING A SIGNIFICANT EFFECT ON DISCHARGE OF POLLUTANTS.
- B. INSPECTIONS INDICATE THE SWPPP IS NOT EFFECTIVE.
- C. A WATER QUALITY STANDARD CHANGES AND THE MPCA DETERMINES THE SWPPP SHALL BE AMENDED TO COMPLY.

A DESCRIPTION OF ANY CHANGE TO THE SWPPP, ALONG WITH THE DATE AND NAME OF THE REVISION SHALL BE RECORDED AND INCLUDED WITH THE SWPPP AND RETAINED ON SITE. THE OWNER SHALL RETAIN ALL RECORDS AFTER COMPLETION OF THE PROJECT.

SITE PLANS

THE CONTRACTOR SHALL PREPARE AND SUBMIT A SITE MANAGEMENT PLAN FOR CONCRETE MANAGEMENT, CONCRETE SLURRY APPLICATION AREAS, WORK IN AND NEAR AREAS OF ENVIRONMENTAL SENSITIVITY, DEWATERING AREAS, AREAS IDENTIFIED AS "SITE MANAGEMENT PLAN AREAS" AND AS REQUESTED BY THE OWNER'S REPRESENTATIVE. SUBMIT ALL SITE MANAGEMENT PLANS IN WRITING AND ALLOW A MINIMUM OF 7 DAYS FOR REVIEW BY THE OWNER'S REPRESENTATIVE. WORK SHALL NOT BE ALLOWED TO COMMENCE IF A SITE MANAGEMENT PLAN IS REQUIRED UNTIL ACCEPTANCE HAS BEEN GRANTED BY THE OWNER'S REPRESENTATIVE.

ENVIRONMENTAL REVIEW

THE REQUIREMENTS OF MINNEHAHA CREEK WATERSHED DISTRICT AND THE MINNEAPOLIS PARK AND RECREATION BOARD ARE SATISFIED BY THE PERMANENT BMPs LISTED ABOVE AND THE TEMPORARY MEASURES INCLUDED. THERE ARE NO ADDITIONAL STORMWATER MITIGATION MEASURES REQUIRED AS A RESULT OF AN ENVIRONMENTAL, ARCHAEOLOGICAL OR AGENCY REVIEW.

DRINKING WATER SOURCE MANAGEMENT AREA (DWSMA), EMERGENCY RESPONSE AREA (ERA) AND KARST REGIONS

THE PROJECT IS LOCATED IN A DWSMA THAT IS CLASSIFIED AT MODERATELY VULNERABLE.

SOIL TYPES

SOIL TYPES FOUND ON SITE ARE PREDOMINATELY LOAMY SAND AND URBAN FILL.

SEE SPECIAL PROVISIONS FOR ADDITIONAL WATER RELATED PERMITS SUCH AS WATERSHED DISTRICT PERMITS, WETLAND PERMITS, ARMY CORPS OF ENGINEERS OR DNR PUBLIC WATERS WORK PERMIT.

FOR PUBLIC WATERS IN WHICH THE DNR HAS PROMULGATED "WORK IN WATER RESTRICTIONS" NO WORK SHALL OCCUR IN LAKES FROM APRIL 1 - JUNE 30, IN NON-TROUT STREAMS FROM MARCH 15 - JUNE 15 OR IN TROUT STREAMS FROM SEPTEMBER 1 - APRIL 1. SEE DNR PERMIT FOR ADDITIONAL INFORMATION.

LAND FEATURE CHANGES

TOTAL DISTURBED AREA: 3.80 ACRES

TOTAL EXISTING IMPERVIOUS SURFACE AREA: 0.01 ACRES

TOTAL PROPOSED IMPERVIOUS SURFACE AREA: 0.00 ACRES

TOTAL PROPOSED NET CHANGE IN IMPERVIOUS SURFACE AREA: -0.01 ACRES

PROJECT CONTACTS

THE OWNER AND CONTRACTOR ARE RESPONSIBLE FOR THE IMPLEMENTATION OF THE SWPPP AND INSTALLATION, INSPECTION, AND MAINTENANCE OF THE EROSION PREVENTION AND SEDIMENT CONTROL BMPs BEFORE, DURING AND AFTER CONSTRUCTION UNTIL THE NOTICE OF TERMINATION HAS BEEN FILED.

ORGANIZATION	CONTACT NAME	PHONE
MINNEAPOLIS PARK AND RECREATION BOARD	JON DUESMAN	612-230-6471
MINNEHAHA CREEK WATERSHED DISTRICT	ELIZABETH SHOWALTER	952-641-4518
MINNESOTA DEPARTMENT OF NATURAL RESOURCES	PETER LEETE	651-366-3634
MINNESOTA POLLUTION CONTROL AGENCY	AMY DALBECQ	651-757-2446
SRF WATER RESOURCES	LEAH GIFFORD	763-475-0010
MNDNR AREA HYDROLOGIST	JASON SPIEGEL	651-259-5822
MNDNR-AIS SPECIALIST	KEEGAN LUND	651-259-5826

MPCA DUTY OFFICER 24 HOUR EMERGENCY NOTIFICATION: 651-649-5451
800-422-0798

LOCATION OF SWPPP REQUIREMENTS

THE REQUIRED SWPPP ELEMENTS MAY BE LOCATED IN MANY PLACES WITHIN THE PLAN SET AS WELL AS IN THE SPECIAL PROVISIONS, MNDOT SPEC BOOK (2018 EDITION), CONSTRUCTION DIARIES OR ON FILE WITH THE PROJECT OWNER. THE NOTES AND TABLE BELOW ARE INTENDED TO BE A QUICK REFERENCE FOR THE CONTRACTOR AND OWNER'S REPRESENTATIVE TO USE IN THE FIELD. THERE MAY BE ADDITIONAL REQUIRED SWPPP ELEMENTS INCLUDED ON THE PROJECT THAT ARE NOT LISTED ON THIS SHEET. IN ADDITION, THE MINNESOTA NPDES/SDS CONSTRUCTION STORMWATER GENERAL PERMIT (NPDES PERMIT) SHOULD BE REVIEWED AND CONSULTED BY THE EROSION AND SEDIMENT CONTROL SUPERVISOR.

LOCATION OF SWPPP REQUIREMENTS IN PROJECT PLAN

DESCRIPTION	LOCATION
PERMANENT EROSION AND SEDIMENT CONTROL MEASURES	SHEET NOS. 4 TO 18
FINAL STABILIZATION	SHEET NOS. 4 TO 18
SOILS AND CONSTRUCTION NOTES	SHEET NOS. 2
DRAINAGE STRUCTURES	SHEET NOS. 25
STORM SEWER PROFILE SHEETS	SHEET NOS. 25
EROSION AND SEDIMENT CONTROL DETAILS	SHEET NOS. 22 TO 23

SITE MAPS AND DESIGN CALCULATIONS

IN ADDITION TO WHAT IS LOCATED WITHIN THIS PLAN, SITE MAPS AND QUANTITIES ARE AVAILABLE UPON REQUEST. PLEASE CONTACT THE OWNER'S REPRESENTATIVE WITH ANY QUESTIONS REGARDING THE SITE MAPS OR CALCULATIONS.

SEAN JERGENSE | 10/10/2018 11:56:57 AM
21.05 (LMS TECH) | C:\Users\sjergense\AppData\Local\Temp\Rooming\Autodesk\C3D_2017\enu\H:\Projects\10000\10547\CAD_BIM\PLAN\10547_SWP.dwg:SWP-01

NO	DATE	BY	CKD	APPR

I hereby certify that this plan, specification, or report was prepared by me or under my direct supervision and that I am a duly Licensed Professional Engineer under the laws of the State of Minnesota.
Print Name: LEAH GIFFORD
Date 6/1/2018 License # #####

DRAWN BY
M. MCGINN
DESIGNED BY
M. MCGINN
CHECKED BY
L. GIFFORD
COMM. NO. 10547



MINNEAPOLIS PARK & RECREATION BOARD
SWPPP
LAKE NOKOMIS SHORELINE ENHANCEMENT

SHEET
33
OF
35

STORM WATER POLLUTION PREVENTION PLAN (SWPPP) NARRATIVE (SHEET 2 OF 3)

GENERAL SWPPP NOTES FOR CONSTRUCTION ACTIVITY

1. THE GENERAL CONTRACTOR SHALL BE RESPONSIBLE TO COMPLY WITH ALL ASPECTS OF THE NPDES CONSTRUCTION STORMWATER PERMIT AT ALL TIMES UNTIL THE NOTICE OF TERMINATION (NOT) HAS BEEN FILED WITH THE MPCA (FORM IS AVAILABLE FROM MPCA WEBSITE). THE CONTRACTOR SHALL DEVELOP A CHAIN OF COMMAND WITH ALL OPERATORS ON THE SITE TO ENSURE THAT THE SWPPP SHALL BE IMPLEMENTED AND STAY IN EFFECT UNTIL THE CONSTRUCTION PROJECT IS COMPLETE, THE ENTIRE SITE HAS UNDERGONE FINAL STABILIZATION, AND THE NOTICE OF TERMINATION (NOT) HAS BEEN SUBMITTED TO THE MPCA.
2. THE CONTRACTOR SHALL PREPARE A WRITTEN, NOT ORAL, WEEKLY SCHEDULE OF PROPOSED EROSION CONTROL ACTIVITIES FOR THE OWNER'S REPRESENTATIVE APPROVAL AS PER MNDOT SPEC. 1717.2.
3. BURNING OF ANY MATERIAL IS NOT ALLOWED WITHIN PROJECT BOUNDARY.
4. THE CONTRACTOR SHALL PLACE STABILIZED CONSTRUCTION EXITS, AS NECESSARY, TO PREVENT TRACKING OF SEDIMENT ONTO PAVED SURFACES AND IN COMPLIANCE WITH THE NPDES PERMIT. STABILIZED CONSTRUCTION EXITS SHALL BE SUFFICIENTLY SIZED AND MAINTAINED TO PREVENT TRACK OUT. STABILIZED CONSTRUCTION EXITS SHALL BE INCIDENTAL.
5. ALL TOPSOIL IN DISTURBED AREAS SHALL BE REMOVED AND STOCKPILED FOR LATER PLACEMENT. AVOID COMPACTION AS MUCH AS IS FEASIBLE IN ALL AREAS WHERE COMPACTION IS NOT REQUIRED FOR CONSTRUCTION. COMPACTION SHALL BE AVOIDED IN ALL AREAS DESIGNATED FOR INFILTRATION.
6. DO NOT DISTURB AREAS OUTSIDE OF THE CONSTRUCTION LIMITS. DELINEATE AREAS NOT TO BE DISTURBED PRIOR TO STARTING GROUND DISTURBING ACTIVITIES. IF IT BECOMES NECESSARY TO DISTURB AREAS OUTSIDE OF THE CONSTRUCTION LIMITS OBTAIN WRITTEN PERMISSION PRIOR TO PROCEEDING. PRESERVE ALL BUFFERS (IF ANY) SHOWN ON THE PLANS.
7. DIRECT DISCHARGES FROM BMPS TO VEGETATED AREAS AND ROUTE STORMWATER AROUND UNSTABILIZED AREAS OF THE SITE WHENEVER POSSIBLE. PROVIDE EROSION CONTROL AND VELOCITY DISSIPATION DEVICES AS NEEDED TO PREVENT EROSION AND NUISANCE CONDITIONS.
8. PROVIDE STABILIZATION IN ANY TRENCHES CUT FOR DEWATERING OR SITE DRAINING PURPOSES.
9. TEMPORARY DEWATERING ACTIVITIES MAY BE REQUIRED. THEREFORE, IT IS POSSIBLE THAT A PERMIT FOR THE TEMPORARY APPROPRIATION OF WATERS OF THE STATE FROM MNDNR SHALL BE REQUIRED FOR THIS PROJECT. THE CONTRACTOR SHALL BE RESPONSIBLE FOR OBTAINING THIS PERMIT (FORMS ARE AVAILABLE FROM THE MNDNR WEBSITE). ALL TEMPORARY DEWATERING SHALL BE DISCHARGED TO AN APPROVED LOCATION FOR TREATMENT PRIOR TO DISCHARGE TO THE RECEIVING WATER. THE CONTRACTOR SHALL BE REQUIRED TO SUBMIT SITE MANAGEMENT PLANS TO THE OWNER'S REPRESENTATIVE FOR APPROVAL PRIOR TO COMMENCING WORK ACCORDING TO SPEC 1717.2. TEMPORARY DEWATERING SHALL BE INCIDENTAL.
10. BASIN DRAINING ACTIVITIES OF TURBID OR SEDIMENT LADEN WATER SHALL BE DISCHARGED TO TEMPORARY SEDIMENT BASINS WHENEVER POSSIBLE. IN THE EVENT THAT IT IS NOT POSSIBLE TO DISCHARGE THE SEDIMENT LADEN WATER TO A TEMPORARY SEDIMENT BASIN THE WATER SHALL BE TREATED SO THAT IT DOES NOT CAUSE A NUISANCE CONDITION IN THE RECEIVING WATERS OR TO DOWNSTREAM LANDOWNERS.
11. IT IS NOT ANTICIPATED THAT POLYMERS, FLOCCULANTS OR OTHER SEDIMENTATION TREATMENT CHEMICALS SHALL BE USED. HOWEVER, IF THE USE OF SUCH CHEMICALS BECOMES NECESSARY TO COMPLY WITH PERMIT REQUIREMENTS, IT SHALL BE IN ACCORDANCE WITH THE NPDES PERMIT.

POLLUTION PREVENTION NOTES

1. THE CONTRACTOR SHALL COMPLY WITH THE REQUIREMENTS REGARDING POLLUTION PREVENTION MANAGEMENT DURING CONSTRUCTION, WHICH SHALL INCLUDE, BUT NOT BE LIMITED TO, PROVIDING THE FOLLOWING (ITEMS LISTED ARE INCIDENTAL):
 - A. WASHOUT AREAS FOR CONCRETE, STUCCO, PAINT, FORM RELEASE OILS, CURING COMPOUNDS AND OTHER CONSTRUCTION MATERIALS FOR USE BY ALL SUBCONTRACTORS AND MATERIAL TESTING PERSONNEL. LOCATION OF WASHOUT AREAS SHALL BE IDENTIFIED BY SIGNAGE AND SHALL BE AT LEAST 200 FT FROM SITE MANAGEMENT PLAN REQUIREMENT AREAS (IF APPLICABLE) OR ENVIRONMENTALLY SENSITIVE AREAS, AND UTILIZE A LEAK-PROOF CONTAINMENT FACILITY OR IMPERMEABLE LINER THAT PREVENTS RUNOFF ONTO ADJACENT SOILS. AN ENGINEERED COLLECTION SYSTEM CAN ALSO BE USED IF IT IS APPROVED BY THE OWNER'S REPRESENTATIVE.
 - B. THE CONTRACTOR SHALL OBTAIN APPROVAL FROM THE OWNER'S REPRESENTATIVE FOR A CHEMICAL STORAGE AREA AND SHALL DESIGNATE AN AREA FOR FUELING AND MINOR MAINTENANCE OF CONSTRUCTION VEHICLES (INCLUDING WASHING) WITH MEANS TO CAPTURE ANY FUEL SPILLS. RUNOFF SHALL BE CONTAINED IN A TEMPORARY SEDIMENT BASIN OR OTHER EFFECTIVE CONTROL AND ALL WASTE GENERATED SHALL BE PROPERLY DISPOSED OF. NO ENGINE DEGREASING IS ALLOWED ON SITE.
 - C. SOLID WASTE COLLECTION AND REMOVAL.
 - D. SECONDARY CONTAINMENT FOR STORAGE OF HAZARDOUS MATERIALS.
 - E. SECURED HAZARDOUS WASTE STORAGE CONTAINERS.
 - F. CHEMICAL SPILL KITS (SHALL BE PROVIDED AT EACH LOCATION WHERE CHEMICALS ARE USED OR STORED AND ANY LOCATION WHERE VEHICLES ARE FUELED OR MAINTAINED).
 - G. PORTABLE RESTROOM FACILITIES THAT ARE ANCHORED TO PREVENT TIPPING.

POLLUTION PREVENTION NOTES (CONT.)

2. CHEMICALS SHALL BE KEPT IN A SECURE STORAGE AREA WITH RESTRICTED ACCESS IN SEALED CONTAINERS WHEN NOT IN USE. RETURN ALL CHEMICALS TO THE DESIGNATED STORAGE AREA BY THE END OF THE DAY UNLESS INFEASIBLE. CHEMICAL STORAGE CONTAINERS SHALL HAVE SECONDARY CONTAINMENT WHEN BEING USED OR STORED ON THE PROJECT SITE, AND PRODUCTS OR CHEMICALS THAT MAY LEACH POLLUTANTS SHALL BE UNDER COVER (PLASTIC SHEETING OR TEMPORARY ROOF). CHEMICAL SPILLS OF ANY KIND (OIL, FUEL, FERTILIZER, ETC.) SHALL BE CLEANED UP AND REMOVED FROM THE SITE IMMEDIATELY. THE CONTRACTOR SHALL HAVE A SPILL KIT ON SITE AT ALL TIMES.
3. THE CONTRACTOR SHALL BE RESPONSIBLE FOR CREATING AND FOLLOWING A WRITTEN DISPOSAL PLAN FOR ALL HAZARDOUS WASTE MATERIALS. THE PLAN SHALL INCLUDE HOW THE MATERIAL SHALL BE DISPOSED OF AND THE LOCATION OF THE DISPOSAL SITE AND SHALL BE SUBMITTED TO THE ENGINEER PRIOR TO WORK ON SITE. LEAKS, SPILLS, OR OTHER RELEASES SHALL BE RESPONDED TO IN ACCORDANCE WITH MPCA SPILL CONTAINMENT AND REMEDIAL ACTION PROCEDURES.
4. THE CONTRACTOR SHALL USE METHODS AND OPERATIONAL PROCEDURES THAT PREVENT DISCHARGE OR PLACEMENT OF BITUMINOUS GRINDINGS, CUTTINGS, MILLINGS, AND OTHER BITUMINOUS WASTES FROM AREAS OF EXISTING OR FUTURE VEGETATED SOILS, AND ALL WATER CONVEYANCE SYSTEMS, INCLUDING INLETS, DITCHES AND CURB FLOW LINES.
5. THE CONTRACTOR SHALL USE METHODS AND OPERATIONAL PROCEDURES THAT PREVENT CONCRETE DUST, PARTICLES, SAW CUT SLURRY, PLANING WASTE AND OTHER CONCRETE WASTES FROM LEAVING PUBLIC RIGHT OF WAY, DEPOSITING IN EXISTING OR FUTURE VEGETATED AREAS OR ENTERING STORMWATER CONVEYANCE SYSTEM INCLUDING INLETS AND CURB FLOW LINES. ONSITE RELEASE OF CONCRETE SLURRY IS PERMISSIBLE IF MINNESOTA POLLUTION CONTROL GUIDANCE FOR ROAD CONSTRUCTION CONCRETE SLURRY AND THE REQUIREMENTS OF THE SPECIAL PROVISIONS ARE FOLLOWED.

EROSION CONTROL SUPERVISOR, INSPECTIONS AND MAINTENANCE NOTES

1. IN ACCORDANCE WITH SPEC. 2573.3 A1, THE CONTRACTOR SHALL PROVIDE A CERTIFIED EROSION CONTROL SUPERVISOR IN GOOD STANDING WHO IS KNOWLEDGEABLE AND EXPERIENCED IN THE APPLICATION OF EROSION PREVENTION AND SEDIMENT CONTROL BMPS. PROVIDE PROOF OF CERTIFICATION (UNIVERSITY OF MINNESOTA - CONSTRUCTION SITE MANAGEMENT) AT THE PRECONSTRUCTION MEETING. WORK SHALL NOT BE ALLOWED TO COMMENCE UNTIL PROOF OF CERTIFICATION HAS BEEN PROVIDED. THE EROSION CONTROL SUPERVISOR IS INCIDENTAL.
2. THE EROSION CONTROL SUPERVISOR SHALL WORK WITH THE OWNER'S REPRESENTATIVE TO OVERSEE THE IMPLEMENTATION OF THE SWPPP AND THE INSTALLATION, INSPECTION, AND MAINTENANCE OF THE EROSION PREVENTION AND SEDIMENT CONTROL BMPS BEFORE, DURING AND AFTER CONSTRUCTION UNTIL THE NOTICE OF TERMINATION (NOT) HAS BEEN FILED WITH THE MPCA.
3. THE EROSION CONTROL SUPERVISOR IS RESPONSIBLE FOR COMPLYING WITH ALL THE INSPECTION AND MAINTENANCE REQUIREMENTS STATED IN THE NPDES PERMIT. INSPECTIONS OF THE ENTIRE CONSTRUCTION SITE SHALL OCCUR A MINIMUM OF ONCE EVERY SEVEN DAYS (3 DAYS FOR PROHIBITED WATERS) DURING ACTIVE CONSTRUCTION AND WITHIN 24 HOURS AFTER A RAINFALL EVENT GREATER THAN 0.5 INCHES IN 24 HOURS (IN NO CASE SHALL THE TIME BETWEEN INSPECTIONS EXCEED 7 DAYS; 3 DAYS FOR PROHIBITED WATERS). RAINFALL AMOUNTS SHALL BE OBTAINED USING A PROPERLY MAINTAINED RAIN GAUGE ONSITE OR BY A WEATHER STATION THAT IS WITHIN ONE MILE. THE EROSION CONTROL SUPERVISOR SHALL THOROUGHLY INSPECT ALL EROSION PREVENTION AND SEDIMENT CONTROL BMPS TO ENSURE INTEGRITY AND EFFECTIVENESS OF EACH BMP.
4. ALL INSPECTIONS AND MAINTENANCE CONDUCTED DURING CONSTRUCTION SHALL BE RECORDED IN WRITING WITHIN 24 HOURS AND THESE RECORDS SHALL BE RETAINED WITH THE SWPPP. INSPECTION REPORTS SHALL BE SUBMITTED TO THE OWNER'S REPRESENTATIVE AND SWPPP DESIGNER IN A FORMAT APPROVED BY THE ENGINEER. INSPECTION RECORDS SHALL INCLUDE:
 - A. DATE AND TIME OF INSPECTIONS;
 - B. NAME OF PERSONS CONDUCTING INSPECTIONS;
 - C. FINDINGS OF INSPECTIONS, INCLUDING RECOMMENDATIONS FOR CORRECTIVE ACTIONS;
 - D. CORRECTIVE ACTIONS TAKEN INCLUDING DATES, TIMES, AND THE PARTY COMPLETING MAINTENANCE ACTIVITIES;
 - E. DATE AND AMOUNT OF ALL RAINFALL EVENTS GREATER THAN 0.5 INCH IN 24 HOURS;
 - F. LOCATION, DESCRIPTION AND PHOTO OF ANY DISCHARGES OFF THE PROJECT SITE.
 - G. DOCUMENTS AND CHANGES MADE TO THE SWPPP.

SEAN JERCENS | 10/10/2018 11:56:57 AM
 21.05 (LMS TECH) | C:\Users\sjercens\AppData\Roaming\Autodesk\CAD_2017\enu\H:\Projects\10000\10547\CAD_BIM\Plan\10547_SWP.dwg;SWP-02

NO	DATE	BY	CKD	APPR

H:\PROJECTS\10000\10547\CAD_BIM\PLAN\10547_SWP.DWG: SWP-02

I hereby certify that this plan, specification, or report was prepared by me or under my direct supervision and that I am a duly Licensed Professional Engineer under the laws of the State of Minnesota.
 Print Name: LEAH GIFFORD
 Date 6/1/2018 License # #####

DRAWN BY
M. MCGINN
 DESIGNED BY
M. MCGINN
 CHECKED BY
L. GIFFORD
 COMM. NO. 10547



MINNEAPOLIS PARK & RECREATION BOARD
 SWPPP
LAKE NOKOMIS SHORELINE ENHANCEMENT

SHEET
34
 OF
35

STORM WATER POLLUTION PREVENTION PLAN (SWPPP) NARRATIVE (SHEET 3 OF 3)

EROSION CONTROL SUPERVISOR, INSPECTIONS AND MAINTENANCE NOTES (CONT.)

5. THE CONTRACTOR SHALL COMPLY WITH THE FOLLOWING INSPECTION AND MAINTENANCE REQUIREMENTS (INSPECTIONS MAY BE REDUCED UNDER CERTAIN CONDITIONS AS COVER IS ESTABLISHED AND CONDITIONS CHANGE AS DESCRIBED IN THE NPDES PERMIT):
 - A. SILT FENCE SHALL BE REPAIRED, REPLACED OR SUPPLEMENTED WHEN IT BECOMES NONFUNCTIONAL OR SEDIMENT REACHES 1/2 THE HEIGHT OF THE SILT FENCE.
 - B. INLET PROTECTION DEVICES SHOULD BE REPAIRED WHEN THEY BECOME NONFUNCTIONAL OR SEDIMENT REACHES 1/2 THE HEIGHT AND/OR DEPTH OF THE DEVICE.
 - C. TEMPORARY SEDIMENT BASINS, IF REQUIRED, SHALL HAVE THE SEDIMENT REMOVED ONCE THE SEDIMENT HAS REACHED 1/2 THE STORAGE VOLUME.
 - D. REMOVE ANY SEDIMENT DEPOSITED IN SURFACE WATERS. SEDIMENT SHALL BE REMOVED AND ANY AREA DISTURBED BY THE REMOVAL RESTABILIZED WITHIN 7 DAYS OF DISCOVERY. A SITE MANAGEMENT PLAN IS REQUIRED FOR WORK IN ANY SURFACE WATER AND APPROPRIATE AUTHORITIES SHALL BE CONTACTED PRIOR TO COMMENCING WORK.
 - E. TRACKED SEDIMENT SHALL BE REMOVED WITHIN 24 HOURS OF DISCOVERY OF TRACKING ONTO PAVED SURFACES.
 - F. ALL NONFUNCTIONAL BMPS SHALL BE REPAIRED, REPLACED, OR SUPPLEMENTED BY THE END OF THE NEXT BUSINESS DAY AFTER DISCOVERY (UNLESS NOTED OTHERWISE ABOVE).
 - G. REINSTALL AS QUICKLY AS POSSIBLE ANY BMP REMOVED TO ACCOMMODATE SHORT TERM ACTIVITIES.
 - H. CONTRACTOR SHALL BE RESPONSIBLE FOR MAINTAINING ALL BMPS UNTIL WORK HAS BEEN COMPLETED, SITE HAS GONE UNDER FINAL STABILIZATION, AND THE NOTICE OF TERMINATION HAS BEEN SUBMITTED TO THE MPCA IN ACCORDANCE WITH THE NPDES PERMIT. SEDIMENT REMOVAL AND MAINTENANCE OF BMPS IS INCIDENTAL.
6. CLEAN OUT ALL PERMANENT STORMWATER BASINS REGARDLESS OF WHETHER USED AS A TEMPORARY SEDIMENT BASIN OR SEDIMENT TRAP TO THE DESIGN CAPACITY AFTER ALL UPGRADIENT LAND DISTURBING ACTIVITY IS COMPLETED.

STABILIZATION AND SEDIMENT CONTROL NOTES

1. THE EROSION PREVENTION AND SEDIMENT CONTROL BMPS SHALL BE PLACED AS NECESSARY TO MINIMIZE EROSION FROM DISTURBED SURFACES AND CAPTURE SEDIMENT ONSITE. ALL EROSION CONTROL MEASURES SHALL BE IN PLACE PRIOR TO ANY REMOVAL WORK AND/OR GROUND DISTURBING ACTIVITIES AND SHALL BE MAINTAINED UNTIL THE POTENTIAL FOR EROSION HAS BEEN ELIMINATED. IF SEDIMENT CONTROLS ARE OVERLOADED (BASED ON FREQUENT FAILURE OR EXCESSIVE MAINTENANCE), ADDITIONAL UPGRADIENT OR REDUNDANT BMPS SHALL BE PLACED.
2. SEDIMENT CONTROL DEVICES SHALL BE ESTABLISHED ON ALL DOWN GRADIENT PERIMETERS BEFORE ANY UP GRADIENT LAND DISTURBING ACTIVITIES BEGIN. SEDIMENT CONTROL DEVICES INCLUDE, BUT ARE NOT LIMITED TO THE FOLLOWING:
 - A. PERIMETER CONTROL SHALL BE LOCATED ON THE CONTOUR TO CAPTURE OVERLAND, LOW-VELOCITY SHEET FLOWS DOWN GRADIENT OF ALL EXPOSED SOILS AND PRIOR TO DISCHARGING TO SURFACE WATERS. THE BMP SHALL BE J-HOOKED AT A MAXIMUM OF 100 FOOT INTERVALS AND EACH SECTION SHALL CONTAIN NO MORE THAN 1/4 ACRE OF DRAINAGE AREA.
 - B. SEDIMENT DAMAGE FROM STOCKPILES SHALL BE MINIMIZED BY PLACING A ROW OF SUPER DUTY SILT FENCE A MINIMUM 5 FEET FROM THE TOE. IF THERE IS NOT ADEQUATE PROJECT AREA TO PLACE THE SILT FENCE MORE THAN 5 FEET FROM THE TOE OF THE SLOPE, THE CONTRACTOR MAY SUBMIT AN ALTERNATIVE TO THE OWNER'S REPRESENTATIVE FOR APPROVAL.
 - C. DITCH CHECKS (IF REQUIRED) SHALL BE PLACED AS INDICATED ON THE PLANS DURING ALL PHASES OF CONSTRUCTION.
 1. TEMPORARY DITCH CHECKS (IF REQUIRED) SHALL CONSIST OF USING ROCK DITCH CHECKS, SEDIMENT CONTROL LOGS AND ROCK WEEPERS IN FRONT OF CULVERT INLETS. IN LIEU OF REMOVING TEMPORARY DITCH CHECKS, THE ROCK MAY BE PUSHED INTO THE GROUND.
 2. FILTER LOGS (IF REQUIRED) SHALL BE PLACED DURING PERMANENT TURF ESTABLISHMENT AT THE INTERVALS IDENTIFIED IN THE PLAN.
 - D. FLOTATION SILT CURTAIN MAY BE USED AS PERIMETER CONTROL BUT ONLY FOR WORK ON THE SHORELINE OR BELOW THE WATERLINE. IMMEDIATELY AFTER THE CONSTRUCTION IN THE AREA IS COMPLETE, AN UPLAND BMP SHALL BE PLACED IF EXPOSED SOILS CONTINUE TO DRAIN TO THE SURFACE WATER.
 - E. TEMPORARY SEDIMENT BASINS ARE REQUIRED WHERE TEN OR MORE ACRES DRAIN TO A COMMON LOCATION (FIVE IF DRAINING TO A SPECIAL OR IMPAIRED WATER).
 1. BASIN VOLUME SHALL BE A MINIMUM OF 1,800 CUBIC FEET PER ACRE OF DRAINAGE AREA TO THE BASIN (3,600 CUBIC FEET PER ACRE IF NO CALCULATIONS ARE PERFORMED)
 2. OUTLET SHALL ALLOW COMPLETE DRAWDOWN FOR MAINTENANCE AND A STABILIZED OVERFLOW. THE OUTLET SHALL WITHDRAW WATER FROM THE SURFACE EXCEPT DURING FROZEN CONDITIONS.
 3. IF A TEMPORARY BASIN OF THE REQUIRED SIZE IS INFEASIBLE THE REASONS SHALL BE DOCUMENTED IN THE SWPPP AND ALTERNATE BMPS SHALL BE PLACED.

STABILIZATION AND SEDIMENT CONTROL NOTES (CONT.)

3. PRESERVE A NATURAL BUFFER OF AT LEAST 50 FEET (100 FEET IF WITHIN 1 MILE OF AND DRAINS TO A SPECIAL OR IMPAIRED WATER) BETWEEN DISTURBED AREAS AND FLOWS TO A SURFACE WATER (NOT REQUIRED AT DITCHES OR STORMWATER CONVEYANCE CHANNELS, STORM DRAIN INLETS OR SEDIMENT BASINS). IF A BUFFER IS INFEASIBLE, PROVIDE AS LARGE A BUFFER AS POSSIBLE AND REDUNDANT SEDIMENT CONTROLS.
4. STORM SEWER INLETS SHALL BE PROTECTED AT ALL TIMES WITH THE APPROPRIATE INLET PROTECTION FOR EACH SPECIFIC PHASE OF CONSTRUCTION. PROVIDE INLET PROTECTION DEVICES WITH EMERGENCY OVERFLOW CAPABILITIES. SILT FENCE PLACED IN THE INLET GRATE IS NOT AN ACCEPTABLE INLET PROTECTION BMP FOR GRADING OPERATIONS (THIS BMP SHALL BE ACCEPTED ONLY FOR SHORT INTERVALS DURING MILLING OR PAVING OPERATIONS). INLET PROTECTION DEVICES MAY NEED TO BE PLACED MULTIPLE TIMES IN THE SAME LOCATION OVER THE LIFE OF THE CONTRACT. INLET PROTECTION DEVICES SHALL BE PAID FOR ONCE PER INLET REGARDLESS OF THE NUMBER OF TIMES THE BMP IS PLACED. ALL STORM SEWER INLET PROTECTION DEVICES SHALL BE KEPT IN GOOD FUNCTIONAL CONDITION AT ALL TIMES. IF THE OWNER'S REPRESENTATIVE DEEMS AN INLET PROTECTION DEVICE TO BE NONFUNCTIONAL, IN POOR CONDITION, INEFFECTIVE OR NOT APPROPRIATE FOR THE CURRENT CONSTRUCTION ACTIVITIES IT SHALL BE REPLACED WITH A SUITABLE ALTERNATIVE AT NO COST TO THE OWNER.
5. PAVEMENT SURFACES SHALL BE SWEEPED WITHIN 24 HOURS OF DISCOVERY OF SEDIMENT OR TRACKING ONTO PAVEMENT THAT DRAINS TO CURB, INLETS, DITCHES OR PONDS. PAVEMENT SHALL BE LIGHTLY WETTED PRIOR TO SWEEPING. THIS WORK IS INCIDENTAL.
6. OUTLETS INTO SURFACE WATERS SHALL BE STABILIZED WITH ENERGY DISSIPATION WITHIN 24 HOURS OF BEING CONSTRUCTED.
7. DITCHES AND EXPOSED SOILS SHALL BE KEPT IN AN EVEN ROUGH GRADED CONDITION IN ORDER TO BE ABLE TO APPLY EROSION CONTROL MULCHES AND BLANKETS.
8. INITIATE STABILIZATION OF ALL EXPOSED SOIL AND STOCKPILE AREAS IMMEDIATELY AFTER CONSTRUCTION ACTIVITY ON THAT PORTION OF THE SITE HAS TEMPORARILY OR PERMANENTLY CEASED. TEMPORARY OR PERMANENT STABILIZATION SHALL BE COMPLETED WITHIN NO MORE THAN 14 DAYS (7 DAYS IF IT IS WITHIN 1 MILE OF AND DRAINS TO A SPECIAL OR IMPAIRED WATER). ALL EXPOSED SOIL WITHIN 200 LINEAL FEET OF AND DRAINING TO A PUBLIC WATER WITH "WORK IN WATER RESTRICTIONS" AND DURING SPECIFIED FISH SPAWNING TIME FRAMES, SHALL BE STABILIZED WITHIN 24 HOURS. IN MANY INSTANCES, THIS SHALL REQUIRE STABILIZATION TO OCCUR MORE THAN ONCE DURING ROUGH GRADING. RAPID STABILIZATION METHOD 3 SHALL BE USED TO PROVIDE TEMPORARY COVER IN THESE AREAS AS APPROPRIATE. SUBSTITUTE SEED MIXTURE 21-112 OR 21-111 FOR THE SPECIFIED SEED MIXTURE AS APPROPRIATE FOR THE SEASON. SEE NPDES PERMIT FOR EXCEPTIONS.
9. THE NORMAL WETTED PERIMETER OF ANY TEMPORARY OR PERMANENT DRAINAGE DITCH THAT DRAINS WATER FROM THE CONSTRUCTION SITE, OR DIVERTS WATER AROUND THE CONSTRUCTION SITE, SHALL BE STABILIZED WITHIN 200 LINEAL FEET FROM THE PROPERTY EDGE OR POINT OF DISCHARGE TO ANY SURFACE WATER. STABILIZATION SHALL OCCUR WITHIN 24 HOURS OF CONNECTION TO A SURFACE WATER, EXISTING GUTTER, STORM SEWER INLET, DRAINAGE DITCH, OR OTHER STORMWATER CONVEYANCE SYSTEM ACCORDING TO SPEC 1717.2. RAPID STABILIZATION METHOD 4 SHALL BE USED TO STABILIZE THESE AREAS (SUBSTITUTE SEED MIXTURE 21-112 OR 21-111 FOR THE SPECIFIED SEED MIXTURE AS APPROPRIATE FOR THE SEASON). THE REMAINDER OF THE DITCH SHALL BE STABILIZED WITHIN 14 DAYS (7 DAYS IF IT IS WITHIN 1 MILE OF AND DRAINS TO A SPECIAL OR IMPAIRED WATER) OF CONNECTING TO THE SURFACE WATER. PERMANENT EROSION CONTROL BLANKET OR RAPID STABILIZATION METHOD 4 (SUBSTITUTE SEED MIXTURE 21-112 OR 21-111 FOR THE SPECIFIED SEED MIXTURE AS APPROPRIATE FOR THE SEASON) SHALL BE USED TO STABILIZE THESE AREAS AS INDICATED IN THE PLANS. IN LOCATIONS WHERE THE DITCH SLOPE IS LESS THAN 2 PERCENT, DISC ANCHORED MULCH AND HYDRAULIC SOIL STABILIZERS MAY BE USED FOR DITCH BOTTOM STABILIZATION AS INDICATED IN THE PLANS OR WITH THE APPROVAL OF THE ENGINEER.
10. ALL EXPOSED SOIL AREAS SHALL BE STABILIZED PRIOR TO THE ONSET OF WINTER. ANY WORK STILL BEING PERFORMED SHALL BE SNOW MULCHED, SEEDED, OR BLANKETED WITHIN THE TIME FRAMES LISTED IN THE NPDES PERMIT.
11. ALL TOPSOIL BERMS SHALL BE STABILIZED AS FOLLOWS:
 - A. BETWEEN APRIL 1 - AUGUST 31, SEED WITH SEED MIXTURE 21-111
 - B. BETWEEN SEPTEMBER 1 AND MARCH 31, SEED WITH SEED MIXTURE 21-112 AND TOP WITH RAPID STABILIZATION 2.
12. TILLING FOR BEDS OR TREE HOLES SHALL BE PLANTED AND MULCHED WITH WOODCHIP WITHIN 7 DAYS OR HYDRO MULCHED UNTIL PLANTING OPERATIONS CAN BE COMPLETED. FILTER LOGS SHALL BE PLACED, AS NEEDED, TO TRAP SEDIMENT ON THE LOWER EDGE OF BEDS OR TREE HOLES. FILTER LOGS SHALL BE LEFT TO PHOTO DEGRADE.

SEAN JERCENS | 10/10/2018 11:56:57 AM
21:05 (LMS TECH) | C:\Users\sjercens\AppData\Roaming\Autodesk\CAD\2017\enu\H:\Projects\10000\10547\CAD_BIM\PLAN\10547_SWP.dwg:SWP-03

NO	DATE	BY	CKD	APPR

I hereby certify that this plan, specification, or report was prepared by me or under my direct supervision and that I am a duly Licensed Professional Engineer under the laws of the State of Minnesota.
 Print Name: LEAH GIFFORD
 Date 6/1/2018 License # #####

DRAWN BY
M. MCGINN
 DESIGNED BY
M. MCGINN
 CHECKED BY
L. GIFFORD
 COMM. NO. 10547



MINNEAPOLIS PARK & RECREATION BOARD
 SWPPP
 LAKE NOKOMIS SHORELINE ENHANCEMENT

SHEET
 35
 OF
 35

Minnesota Wetland Conservation Act

Notice of Decision

Local Government Unit (LGU) Minnehaha Creek Watershed District	Address 15320 Minnetonka Blvd Minnetonka, MN 55345
--	---

1. PROJECT INFORMATION

Applicant Name Minneapolis Park and Recreation Board	Project Name Lake Nokomis Shoreline Enhancement	Date of Application (10/2/2017) Incomplete 10/5/2017 Complete 10/6/2017	Application Number W17-42
<input checked="" type="checkbox"/> Attach site locator map			

Type of Decision:

<input checked="" type="checkbox"/> Wetland Boundary or Type	<input type="checkbox"/> No-Loss	<input type="checkbox"/> Exemption	<input type="checkbox"/> Sequencing
<input type="checkbox"/> Replacement Plan	<input type="checkbox"/> Banking Plan		

Technical Evaluation Panel Findings and Recommendation (if any):

<input type="checkbox"/> Approve	<input type="checkbox"/> Approve with conditions	<input type="checkbox"/> Deny
Summary (or attach):		

2. LOCAL GOVERNMENT UNIT DECISION

Date of Decision: December 6 th , 2017		
<input checked="" type="checkbox"/> Approved	<input type="checkbox"/> Approved with conditions (include below)	<input type="checkbox"/> Denied

LGU Findings and Conclusions (attach additional sheets as necessary):

The Minneapolis Park and Recreation Board has applied for a wetland boundary & type confirmation for the wetlands located at 5001 W Lake Nokomis Parkway (PID 1302824230001) in the City of Minneapolis, Hennepin County, Minnesota. Legal description: Section 13, Township 28N, Range 24W. The boundary & type approval was requested October 2, 2017.

A wetland delineation was conducted by Applied Ecological Services in September 2017. A complete delineation report and WCA application were submitted to MCWD on October 6, 2017. One wetland was delineated within the project area. Wetland 1 was identified as a Type 1, Fresh Wet Meadow wetland.

MCWD staff reviewed the boundaries in the field on November 7th, 2017. MCWD was in agreement with the wetland boundaries and types identified on site.

MCWD approves the wetland boundaries and types as delineated in the field and documented in the delineation report. This decision is valid for five years. A future project located on this property may require a permit from the MCWD.

For Replacement Plans using credits from the State Wetland Bank:

Bank Account #	Bank Service Area	County	Credits Approved for Withdrawal (sq. ft. or nearest .01 acre)

Replacement Plan Approval Conditions. In addition to any conditions specified by the LGU, the approval of a Wetland Replacement Plan is conditional upon the following:

- Financial Assurance:** For project-specific replacement that is not in-advance, a financial assurance specified by the LGU must be submitted to the LGU in accordance with MN Rule 8420.0522, Subp. 9 (List amount and type in LGU Findings).
- Deed Recording:** For project-specific replacement, evidence must be provided to the LGU that the BWSR “Declaration of Restrictions and Covenants” and “Consent to Replacement Wetland” forms have been filed with the county recorder’s office in which the replacement wetland is located.
- Credit Withdrawal:** For replacement consisting of wetland bank credits, confirmation that BWSR has withdrawn the credits from the state wetland bank as specified in the approved replacement plan.

Wetlands may not be impacted until all applicable conditions have been met!

LGU Authorized Signature:

Signing and mailing of this completed form to the appropriate recipients in accordance with 8420.0255, Subp. 5 provides notice that a decision was made by the LGU under the Wetland Conservation Act as specified above. If additional details on the decision exist, they have been provided to the landowner and are available from the LGU upon request.

Name Heidi Quinn	Title Permitting Technician	
Signature 	Date 12/6/17	Phone Number and E-mail (952) 641-4504 hquinn@minnehahacreek.org

THIS DECISION ONLY APPLIES TO THE MINNESOTA WETLAND CONSERVATION ACT. Additional approvals or permits from local, state, and federal agencies may be required. Check with all appropriate authorities before commencing work in or near wetlands.

Applicants proceed at their own risk if work authorized by this decision is started before the time period for appeal (30 days) has expired. If this decision is reversed or revised under appeal, the applicant may be responsible for restoring or replacing all wetland impacts.

This decision is valid for three years from the date of decision unless a longer period is advised by the TEP and specified in this notice of decision.

3. APPEAL OF THIS DECISION

Pursuant to MN Rule 8420.0905, any appeal of this decision can only be commenced by mailing a petition for appeal, including applicable fee, within thirty (30) calendar days of the date of the mailing of this Notice to the following as indicated:

Check one:

<input checked="" type="checkbox"/> Appeal of an LGU staff decision. Send petition and \$0 fee (if applicable) to: Minnehaha Creek Watershed District 15320 Minnetonka Blvd Minnetonka, MN 55345	<input type="checkbox"/> Appeal of LGU governing body decision. Send petition and \$500 filing fee to: Executive Director Minnesota Board of Water and Soil Resources 520 Lafayette Road North St. Paul, MN 55155
--	---

4. LIST OF ADDRESSEES

<input checked="" type="checkbox"/> SWCD TEP member: Stacey Lijewski- Stacey.lijewski@hennepin.us <input checked="" type="checkbox"/> BWSR TEP member: Ben Carlson – ben.carlson@state.mn.us <input type="checkbox"/> LGU TEP member (if different than LGU Contact): <input checked="" type="checkbox"/> DNR TEP Jason Spiegel- Jason.spiegel@state.mn.us <input checked="" type="checkbox"/> DNR Regional Office (if different than DNR TEP member): Becky Horton – becky.horton@state.mn.us <input type="checkbox"/> WD or WMO (if applicable): <input checked="" type="checkbox"/> Applicant (notice only) and Landowner (if different): Minneapolis Park and Recreation Board- jduesman@minneapolisparcs.org <input checked="" type="checkbox"/> Members of the public who requested notice (notice only): Elizabeth Stout- Elizabeth.stout@minneapolismn.gov; Douglas Mensing- dougm@appliedeco.com <input checked="" type="checkbox"/> Corps of Engineers Project Manager (notice only): Ryan Malterud– Ryan.m.malterud@usace.army.mil <input type="checkbox"/> BWSR Wetland Bank Coordinator (wetland bank plan applications only)
--

5. MAILING INFORMATION

➤ For a list of BWSR TEP representatives: www.bwsr.state.mn.us/aboutbwsr/workareas/WCA_areas.pdf

➤ For a list of DNR TEP representatives: www.bwsr.state.mn.us/wetlands/wca/DNR_TEP_contacts.pdf

➤ Department of Natural Resources Regional Offices:

NW Region: Reg. Env. Assess. Ecol. Div. Ecol. Resources 2115 Birchmont Beach Rd. NE Bemidji, MN 56601	NE Region: Reg. Env. Assess. Ecol. Div. Ecol. Resources 1201 E. Hwy. 2 Grand Rapids, MN 55744	Central Region: Reg. Env. Assess. Ecol. Div. Ecol. Resources 1200 Warner Road St. Paul, MN 55106	Southern Region: Reg. Env. Assess. Ecol. Div. Ecol. Resources 261 Hwy. 15 South New Ulm, MN 56073
---	---	--	--

For a map of DNR Administrative Regions, see: http://files.dnr.state.mn.us/aboutdnr/dnr_regions.pdf

➤ For a list of Corps of Project Managers: www.mvp.usace.army.mil/regulatory/default.asp?pageid=687 or send to:

US Army Corps of Engineers

St. Paul District, ATTN: OP-R
180 Fifth St. East, Suite 700
St. Paul, MN 55101-1678

➤ For Wetland Bank Plan applications, also send a copy of the application to:
Minnesota Board of Water and Soil Resources
Wetland Bank Coordinator
520 Lafayette Road North
St. Paul, MN 55155

6. ATTACHMENTS

In addition to the site locator map, list any other attachments:

Approved wetland boundaries



Hennepin County Natural Resources Map

Date: 12/6/2017

Legend

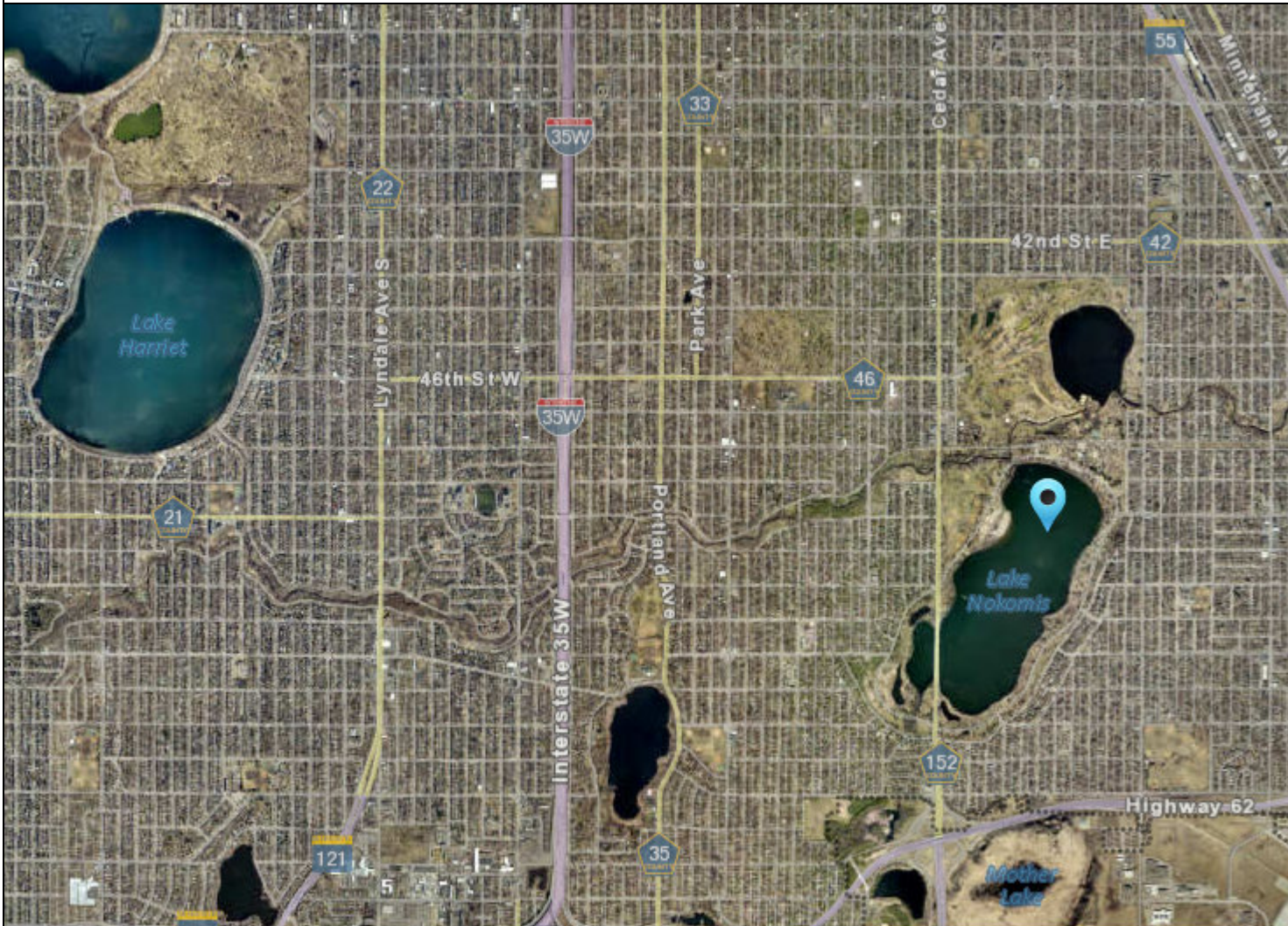

Point Location (UTM 15N): 481119.574, 4973183.997

Comments:

Lake Nokomis Site Location

1 inch = 3,200 feet



This data (i) is furnished 'AS IS' with no representation as to completeness or accuracy, (ii) is furnished with no warranty of any kind; and (iii) is not suitable for legal, engineering or surveying purposes. Hennepin County shall not be liable for any damage, injury or loss resulting from this data.

COPYRIGHT © HENNEPIN COUNTY 2017

Figure 5. Wetland Delineation

